



Sailing to Win  *Sailing for Life*
La voile pour la victoire *La voile pour la vie*

Intermediate Cruising

Student Notes

Third Edition, Revision 2.0

November 2020

This document has been prepared for use in the delivery of SAIL CANADA Intermediate Cruising training. All rights reserved. No part of this publication may be reprinted, reproduced, transmitted, stored in a retrieval system, or otherwise utilized, in any form or means, electronic or mechanical, including photocopying or recording, now existing or hereafter invented for any other purpose, without prior written permission of the publisher. The publisher grants the right to current registered SAIL CANADA Cruising Instructors to copy, print and distribute this document in support of training conducted as part of a SAIL CANADA Learn to Cruise training program.

Editorial First Edition: Marco Coda, Lewis Forth, David Layton, David West, Gillian West, Oliver Woolcock, Larry Young, Peter Rusch.

Editorial Second Edition: Bob Davis, Jamie Gordon, Paul Peachey, Gillian West.

Photos: Bob Davis

Printed in Canada

Copyright © 2019
Third Edition
By Sail Canada
Portsmouth Olympic Harbour
53 Yonge Street
Kingston, Ontario
Canada
K7M 6G4

Tel: (613) 545-3044
Fax: (613) 545-3045

Email: sailcanada@sailing.ca

Introduction and Purpose

The purpose of these notes is to serve as a study guide for the Sail Canada Intermediate Cruising Standard. These notes are designed to be used in conjunction with instructor led classroom and on-water training.

These notes were written by a group of Sail Canada Instructor Evaluators to help cruising students prepare for the standard. Contributors and facilitators included: Marco Coda, Bob Davis, Lewis Forth, Jamie Gordon, David Layton, Paul Peachey, Peter Rusch, David West, Gillian West, Oliver Woolcock and Larry Young.

INTERMEDIATE CRUISING STANDARD

Standard Description

This live-aboard Standard follows the Basic Cruising Standards in the Sail Canada keelboat and cruising training system. Students will participate in operation of the vessel as crew and as skipper. The vessel will be operated under sail and power while making daytime passages. The ability to act as skipper and crew in operation of a sailing vessel by day in unfamiliar waters will be developed, while building the skills and experience needed for live-aboard cruises and bareboat charter.

Practical topics covered include sail selection and use of the jib cars and mainsheet traveler controls to adjust sail shape for efficient propulsion and balance in the conditions encountered. Students will have the opportunity to practice and develop skills manoeuvring the vessel under power for mooring pickup, and accomplishing various anchoring strategies and enhanced docking and dock departure techniques and procedures. Opportunities to practice the navigation skills taught in the Basic Coastal Navigation course including elementary pilotage and passage planning, non-electronic position determination methods and basic use of satellite positioning systems will help to strengthen this knowledge and skillset. Practical knowledge of the use and management of vessel systems will be taught through use of these systems on board while cruising.

Training leading to this Standard build on the skills developed in the Sail Canada Start Keelboat Sailing, Basic Cruising and Basic Coastal Navigation Standards. Candidates are expected to be able to competently demonstrate the skills developed in attaining those Standards..

It is envisioned that the program will be taught in a minimum five days in a live-aboard format. A challenge of the practical component of the standard may be accomplished through a 48 hour live-aboard skill evaluation.

Objective

To be able to cruise safely as both skipper and crew of a sailing yacht of 9 to 12 meters, sloop rigged with an inboard engine, in moderate wind and sea conditions by day. The Standard emphasizes on-the-water skills at a level acceptable for extended cruises in coastal and inland waters and for bareboat chartering.

Prerequisites

Requirements prior to taking the standard: Sail Canada Basic Cruising Standard; Sail Canada Basic Coastal Navigation Standard or Coastal Navigation Standard; ROC(M) VHF with DSC endorsement; Pleasure Craft Operator's Card (or equivalent).

Recommended prior to taking the standard: Recognized standard first aid and CPR certificate, Sail Canada Intermediate Coastal Navigation Standard.

Note: To maximize the likelihood of successfully completing the Intermediate Cruising Standard, a student should:

- a) Have experience as skipper of at least ten day sails (or equivalent),
- b) Be able to consistently use the knowledge and demonstrate the skills learned in the Basic Cruising Standard and the Basic Coastal Navigation Standard.

ASHORE KNOWLEDGE

Section I: Planning

The candidate must be able to:

1. State the fuel tank capacity and range of the candidate's boat and list what factors could affect the range of the boat under power;
2. State the water capacity of the selected boat and the minimum and typical daily water requirements of a person and methods of conserving water;
3. State the causes, prevention and cures for seasickness and describe the impact seasickness has on crew effectiveness;
4. List the appropriate personal clothing and safety gear for cruising and describe how its choice is related to safety and comfort;
5. Discuss menu planning and relate it to suitability for the day's activities;
6. Describe provisioning requirements and the factors to consider in stocking the vessel;
7. List the minimum contents of a first aid kit for a one-week cruise in coastal or inland waters;
8. Know the spare engine parts one might deem prudent for a one-week cruise in coastal or inland waters;
9. Know the minimum set of tools required for a one-week cruise in coastal or inland waters;
10. Describe the general procedures to be followed and the documents required for entering a country after leaving another country, and the current procedures for marine travel between Canada and the USA.

Section II: Living Afloat & Boat Systems

The candidate must be able to:

11. Discuss galley procedures in order to minimize the danger of fire, scalding or other galley accidents;
12. Describe the common cooking systems (stoves and fuels) with respect to safe procedures for the operation of appliances, including safety checks, igniting appliances and system shut down, convenience, speed of cooking and costs;
13. Discuss the common types of cabin heaters with respect to safety, convenience and cost;
14. Describe the principle elements of the 120V and 12V vessel systems, their use, and considerations for proper battery management;
15. Describe refrigeration system types and state two ways to conserve power when a vessel is equipped with an electric refrigeration system;
16. Describe water distribution systems with multiple tanks and various styles of pumps;
17. Describe the proper operating procedures for the head and holding tank, list the precautions necessary to prevent malfunction and identify issues relating to holding tank capacity;
18. Identify boating environmental issues, with particular reference to responsible disposal of waste and management of pollutants;
19. Describe the safe operation of an anchor windlass, including appropriate vessel handling while using this equipment;
20. Differentiate between various sail handling systems and discuss handling and operational considerations of a particular combination of systems including furling systems (foresail, mainsail in mast, mainsail in boom) and mainsail flaking systems.

Section III: Weather

The candidate must be able to:

21. Describe the effect of local heating and cooling of land and water as related to wind and cloud formation;
22. Identify conditions likely to lead to fog.
23. Describe the effects of wind against current.

Section IV: Seamanship

The candidate must be able to:

24. Describe the complete actions to be taken for the following:
 - a) Springing a leak,
 - b) Steering fails,
 - c) Grounding,
 - d) Fouling a propeller,
 - e) Dragging anchor,
 - f) Collision with another vessel,
 - g) Fire,
 - h) Propane leak,
 - i) Engine failure in an anchorage too crowded to permit safe sailing,
 - j) Engine failure in a busy channel,
 - k) Engine cooling water fails to flow;
25. Describe in detail two methods of getting a crew overboard back aboard;
26. Describe three methods of recovering fouled anchors;
27. Describe options for stowing and securing a dinghy when snugging down for the night;
28. Describe handling considerations (including stowage, launching/retrieving and towing) and differences between an inflatable dinghy, a rigid inflatable boat (RIB) and a rigid dinghy;
29. Describe precautions for safe handling of an outboard motor for the tender and actions to take in the event of accidental submersion;
30. Describe the methods of rafting at anchor and dangers involved;
31. State the factors to be considered before allowing anyone to go swimming while the boat is at anchor;
32. Describe the information required and the procedures to be followed when tying a boat to a fixed dock in local tidal conditions;
33. Describe how to secure the boat with an anchor on the bow or stern and the other end made fast to dock or shore;
34. Describe a seamanlike method of preparing a boat in order that it may be left at the dock or on a mooring for a period of a week or more without crew;
35. Describe the responsibilities of skipper and crew for the following courtesies, customs and legal obligations:
 - a) Permission to board,
 - b) Permission and entitlement to come alongside,
 - c) Courtesy in crossing adjacent boats when rafted,
 - d) Rights of first boat at an anchorage,
 - e) Keeping clear of boats racing (even though cruising boats may be the stand-on vessel),
 - f) Flag etiquette:
 - (i) National Flag,
 - (ii) Courtesy flag,
 - (iii) Burgee / house flag,
 - g) Offering assistance to other yachts in trouble,
 - h) Alcohol consumption;
36. Describe the characteristics, limitations and uses of the following rope:

- a) Polypropylene,
- b) Dacron,

- c) Nylon,
- d) High modulus fibres.

Section V: Navigation & Passage Planning

The candidate must be able to:

- 37. Convert directions between true, magnetic and compass, using the compass rose on a current chart;
- 38. Determine speed, time and distance when two are known;
- 39. Determine estimated time of arrival (ETA) and revised ETA.
- 40. Identify sources of navigation information and use this information in route planning.

Table of Contents

Section I: Planning.....	10
1. State the fuel tank capacity and range of the candidate's boat and list the factors that could affect the range of the boat under power.	10
2. State the water capacity of the selected boat and the minimum daily water requirements of a person and methods of conserving water.....	11
3. State the causes, prevention and cures for seasickness and describe the impact seasickness has on crew effectiveness.	11
4. List the appropriate personal clothing and safety gear for cruising and describe how its choice is related to safety and comfort.....	12
5. Discuss menu planning and relate it to suitability for the day's activities.	12
6. Describe provisioning requirements and the factors to consider in stocking the vessel.	14
7. List the minimum contents of a first aid kit for a one-week cruise.	15
8. Know the spare engine parts one might deem prudent for a one-week cruise.....	15
9. Know the minimum set of tools required for a one-week cruise.	16
10. Describe the general procedures to be followed and the documents required for entering a country after leaving another country, and the current procedures for marine travel between Canada and the USA.	16
Section II: Living Afloat & Boat Systems.....	20
11. Discuss galley procedures in order to minimize the danger of fire, scalding or other galley accidents.	20
12. Describe the common cooking systems (stoves and fuels) with respect to safe procedures for the operation of appliances, including safety checks, igniting appliances and system shut down, convenience, speed of cooking and costs.	21
13. Discuss common types of cabin heaters with respect to safety, convenience and cost.	22
14. Describe the principle elements of the 120V and 12V vessel systems, their use, and considerations for proper battery management.....	24
15. Describe refrigeration system types and state two ways to conserve power when a vessel is equipped with an electric refrigeration system.	26
16. Describe water distribution systems with multiple tanks and various styles of pumps.	27
17. Describe the proper operating procedures for the head and holding tank. List the precautions necessary to prevent malfunction and identify issues relating to holding tank capacity.....	28
18. Identify boating environmental issues, with particular reference to responsible disposal of waste and management of pollutants.	30

19. Describe the safe operation of an anchor windlass, including appropriate vessel handling while using this equipment.....	31
20. Differentiate between various sail handling systems and discuss handling and operational considerations of a particular combination of systems including furling systems (foresail, mainsail in mast, and mainsail in boom) and mainsail flaking systems.....	32
Section III: Weather.....	34
21. Describe the effect of local heating and cooling of the land and water as related to wind and cloud formation.....	34
22. Identify conditions likely to lead to fog.	35
23. Describe the effect of wind against current.	36
Section IV: Seamanship	37
24. Describe the complete actions to be taken for the following:	37
a) Springing a leak,	37
b) Steering fails,.....	37
c) Grounding,	37
d) Fouling a propeller,	37
e) Dragging anchor,	37
f) Collision with another vessel,.....	37
g) Fire,	37
i) Engine failure in an anchorage too crowded to permit safe sailing,	37
j) Engine failure in a busy channel,	37
k) Engine cooling water fails to flow.	37
24 f) Collision with another vessel – A proper lookout combined with appropriate manoeuvring is the best means of preventing collision. According to the International Regulations for the Prevention of Collisions, <i>every vessel shall use all available means appropriate to the prevailing conditions to determine if a risk of collision exists. If there is any doubt, such risks shall be deemed to exist.</i>	38
25. Describe in detail two methods of getting a crew overboard back aboard.	41
26. Describe three methods of recovering fouled anchors.....	45
27. Describe options for stowing and securing a dinghy when snugging down for the night. .	46
28. Describe handling considerations (including stowage, launching/retrieving and towing) and differences between an inflatable dinghy, a rigid inflatable boat (RIB) and a rigid dinghy.	47

29. Describe precautions for safe handling of an outboard motor for the tender and actions to take in the event of accidental submersion.	48
30. Describe the methods of rafting at anchor and dangers involved.	49
31. State the factors to be considered before allowing anyone to go swimming while the boat is at anchor.....	50
32. Describe the information required and the procedures to be followed when tying a boat to a fixed dock in local tidal conditions.	51
33. Describe how to secure the boat with an anchor on the bow or stern and the other end made fast to dock or shore.	52
34. Describe a seamanlike method of preparing a boat in order that it may be left at the dock or on a mooring for a period of a week or more without crew.	54
35. Describe the responsibilities of skipper and crew for the following courtesies, customs and legal obligations.....	55
36. Describe the characteristics, limitations and uses of the following rope:	57
a) Polypropylene,	57
b) Dacron (Polyester),.....	57
c) Nylon,.....	57
d) High modulus fibres (HMDPE).	57
Section V: Navigation and Passage Planning.....	60
37. Convert directions between true, magnetic and compass, using the compass rose on a current chart.	60
38. Determine speed, time and distance when two are known.	62
39. Determine estimated time of arrival (ETA) and revised ETA.....	62
40. Identify sources of navigation information and use this information in route planning....	63
APPENDIX I: PASSAGE & PILOTAGE PLANNING	65
APPENDIX II: SAIL TRIM THEORY.....	68
GLOSSARY:	70
SUPPLEMENTARY PUBLICATIONS:	72

Section I: Planning

1. State the fuel tank capacity and range of the candidate's boat and list the factors that could affect the range of the boat under power.

Fuel capacity and range under power is specific to the vessel. Check the engine manual on board for a fuel consumption graph. In general, engines' fuel consumption curves are cup shaped, being less efficient at lower and higher RPMs than mid-range. Diesel engine specifications typically state consumption in litres per hour. Based on a study of a variety of diesel engine specs, you may optimistically assume a consumption of 0.1 l/hp/hr, or a worse case consumption of 0.2 l/hp/hr.

For a gasoline engine, in absence of a fuel consumption specs, assume 0.3 l/hp/hr, until experience over running hours provides a more reliable estimate.

Always maintain a log of running hours, average speed under power, and of the quantity of fuel purchased. This will also allow you to verify the accuracy of the fuel gauge, if fitted.

A simple formula to calculate range under power is:

$$\text{Range} = \frac{\text{Tank capacity}}{\text{Consumption/hour}} \times \text{Cruising speed}$$

For example, a typical 11 metre boat with a 95-litre fuel tank and a 35-horsepower diesel engine, will burn approximately 3.5 litres of fuel per hour (0.1 l/hp/hr), at a cruising speed of 5 knots. That means a full tank will give 27 hours of running time, for a range of 135 miles.

$$\text{Range} = \frac{95}{3.5} \times 5 = 135 \text{ M}$$

The range of a vessel is influenced by the size of the engine (e.g. horsepower and number of cylinders), tune of the engine, and the RPM at which the engine runs. External factors include:

- Sea state and/or wind direction;
- Current direction;
- Condition and cleanliness of the bottom of the hull;
- Towing a dinghy;
- Ability of the crew on the helm;
- Diameter and pitch of the propeller;
- Motor-sailing may give the boat a "lift";
- The vessel load, with crew, gear and supplies.

When determining range, always include a fuel reserve. One approach is 1/3 out, 1/3 back and 1/3 in reserve. Fuel tanks are constructed so that the fuel pick up pipe does not go all the way to the bottom. This is to prevent sucking up sludge and water from the bottom of the tank. Therefore, you can never use 100% of the fuel. In colder climates range may also be reduced using a diesel heating furnace which generally takes fuel from the same tank(s) as the engine(s).

2. State the water capacity of the selected boat and the minimum daily water requirements of a person and methods of conserving water.

Generally, people will use at least eight litres (2 gallons) of liquids per day, not including showers. The bare minimum would be two litres (0.5 gallons) of water, supplemented by other liquids (fruit juices, soft drinks, etc.).

Cruising boats can vary dramatically in the amount of water they carry in tanks. Refer to the owner's manual or ask the charter company for details on your particular vessel. As an example, tanks on a typical 11 metre boat may hold 276 litres of water. Tanks on a 10-metre boat may hold 174 litres.

Make sure you know how to access and inspect all the water tanks, and how to switch from one to the other.

Methods of conserving water include: not letting taps run while brushing teeth or washing face; showering ashore, swimming, or taking a sponge bath from a small amount of water in a sink; marking cups & glasses for individual reuse without washing; diluting dish soap to minimize suds; using sea or lake water to wash dishes and rinse with small amount of ship's water; not filling the sink to wash dishes; using hand or foot pumps; never run water into a sink unless the plug is in the drain. When brushing your teeth, put water in a glass and use that as the source of water. When washing your face or body, put a little water in the sink and use that water for washing. A good routine is to turn off the pressure water at the electrical panel to prevent accidental loss of water due to crew carelessness or a fault in the water system.

3. State the causes, prevention and cures for seasickness and describe the impact seasickness has on crew effectiveness.

Many sailors suffer from seasickness at one time or another. For some, the illness can be quite mild and only inconvenient, while for others the effects of 'mal de mer' can be quite debilitating and, therefore, present a danger.

Seasickness is caused by mixed messages being sent to the brain about our balance and body position. The balance centre of the inner ear registers all the motion we experience sailing as the boat pitches, rolls and yaws over the sea. If our eyes are focused on the boat and we move with the boat, our vision doesn't register that we are moving. Some of the best ways to avoid or minimize seasickness are therefore ways of avoiding these conflicts. By staying on deck and focusing on the horizon, your eyes acknowledge the motion your inner ear feels, thus reducing the chances of feeling ill. By contrast, staying below decks, cooking, or doing chart work can greatly increase the odds of succumbing to mal de mer.

Before departure, crew members can reduce the odds of falling ill by avoiding rich, fatty or spicy foods and alcohol and coffee, getting plenty of rest, and timing medication as per instructions. Preparing navigation plans and preparing food ahead as well as having foul weather gear and warm clothing handy will help reduce time spent below deck while underway. Avoid discussion of the possibility of seasickness.

There is effective medication to help minimize the effects of seasickness. Any anti-nausea medication should be tested well before it is needed to check for side effects. Sailors with concerns about seasickness should see their doctors for more information.

Ginger root is a natural remedy for nausea, and many sailors report ginger tea to be a good remedy for seasickness. "Sea bands" may also prove helpful.

If, despite the above, you or a member of your crew starts to feel ill on a voyage, the following suggestions should help:

- Keep warm, dry and rested;
- Eat small portions of easily digested food, such as crackers;
- Stay above deck. Steering is often the best cure for seasickness;
- Watch the horizon;
- If you must go below lie down near the middle of the boat where there is the least motion and close your eyes.

If someone on the boat is nauseous and likely to be sick, try to get them on deck, sitting in the cockpit, and leaning over the leeward side of the boat. Make sure the person is secured to the boat. Assign another crew member to assist them if needed.

4. List the appropriate personal clothing and safety gear for cruising and describe how its choice is related to safety and comfort.

Clothing for sailing is similar to that used for other outdoor activities. For a one-week cruise, think in terms of a camping trip. Keep in mind that it is usually cooler on the water than ashore. Dress in layers with a base layer of polypropylene, silk or wool to wick away sweat, mid-layers for insulation and an outer layer that is wind and waterproof. Some guidelines to follow:

- Nonslip footwear, sailing boots and deck shoes (avoid black soled shoes);
- Foul weather gear, floater coat or cruiser suit;
- Warm clothing made of wool or fleece;
- Sailing gloves and a toque or watch cap;
- Lightweight long pants and shirt for sun protection - avoid cotton and jeans;
- Shade or peaked hat;
- Sunglasses;
- Bathing suit and towel;
- Soft duffle bag.

Safety gear should include a PFD for every person that fits and is comfortable to wear on the boat and at least one safety harness, tether and knife.

5. Discuss menu planning and relate it to suitability for the day's activities.

Good food is an enjoyable and fundamental part of sailing and cruising. That said, menu planning should start well in advance of a trip. The first step is to learn about crew and guests'

food allergies and preferences. Next consider what you have to work with on board. Establish how much cold storage there is on the boat, whether there is an icebox or refrigerator. How many stove-top burners can be used at the same time? Do you really want to use the oven and heat up the cabin? What kind of cookware is available? How much time do you want to spend preparing and cooking meals?

Flexibility is essential when menu planning. In cold weather there should be at least one hot meal a day. In warm weather there must be extra drinking water, juices, etc. Plan simple meals with ingredients that can be mixed and matched. Remember, unpredictable weather and sea conditions may result in you having to adjust your meal plans. Normally you will be sailing during the day, so a hearty breakfast followed by a light lunch, afternoon snack and dinner is recommended.

Breakfast can be a very simple self-service meal with fresh fruit, juice, coffee/tea, yogurt, hot or dry cereal, muffins, or croissants. More elaborate breakfasts include French toast, omelets, pancakes, etc.

For lunch consider deli sandwiches or wraps that are easy to serve on deck and can be prepared in advance if anticipating rough sea conditions. If it is cold and raining, the crew and guests will appreciate a cup of hot soup and a hot drink.

Snacks between meals and during watches are crucial for energy and morale. Individually packaged cookies, trail mix, and granola or candy bars are great and stay fresh longer. Sharing an appetizer before dinner is a tradition for many cruisers once moored for the evening. This can be anything from fresh fruit, cheese and crackers, nachos, vegetables and dip, to more palate-pleasing hors d'oeuvres.

Dinners should be healthy, balanced and simple to prepare, keeping in mind the facilities on board. For the first night, bring a pre-cooked meal from home to give everyone a chance to familiarize themselves with the vessel and where things are.

Remember, the key to successful menu planning is advance planning with consideration for the crew and guests' food preferences, and onboard facilities for preparing, cooking and cleaning up.

6. Describe provisioning requirements and the factors to consider in stocking the vessel.

Another important aspect of planning a week-long cruise is careful food provisioning. Sailing makes people hungry so when thinking about the menu and food provisioning always think on the generous side. Running out of food, having food spoil or even forgetting a crucial ingredient can ruin a pleasant holiday. Remember, a well-fed crew is a happy crew.

Provisioning a boat requires some planning and creativity. First, consider the places you will visit and the opportunity for re-provisioning and shore meals. Purchase ingredients once you have determined the number of meals that will be prepared on board and a menu that appeals to everyone.

The challenge with food provisioning is balancing how much to bring and where to store it. Most boat galleys have limited counter space, few cupboards and small fridges so one needs to be diligent with what to take and how to use it. Consider the following tips in stocking the vessel:

- Fresh produce will keep for several days stowed outside the refrigerator;
- Pre-freeze items that can be used later in the week including butter and juice;
- Use a separate cooler for beverages to limit the number of times you have to open your “food” cooler. Drinks stored next to the hull will stay cool;
- Humidity is high on a boat, accelerating mould formation and reducing the shelf life of open packages. In this environment mould forms on bread within days and most perishables will likely have a shorter life than at home. Don’t expect an opened package of crackers to stay fresh for longer than 24 hours;
- Organize lockers based on meals – one for snacks, one for bread and cereal, staples...;
- To minimize dirty dishes, plan meals that can be served twice (e.g. BBQ steaks for dinner and then have steak sandwiches the following day for lunch);
- Prepare meals with fresh foods first. Canned and dried foods will be better towards the end of the week;
- Make sure to bring spices, oil, sugar, butter, milk and other basic ingredients;
- Have a master list of basic food and non-food items for the boat (trash bags, soap, tinfoil, freezer bags, and plastic wrap);
- Remove as much of the food packaging you can before you stow it to reduce garbage;
- Avoid glass bottles and packaging that cannot be re-sealed.

7. List the minimum contents of a first aid kit for a one-week cruise.

Evaluate the first aid kit with regard to special needs of crew, availability of medical assistance and knowledge of the crew. Advise your crew to be sure to bring personal medications with them. The first aid kit should be stored in a watertight container. A list of items to include in a first aid kit for a one-week cruise might include:

- First aid manual
- Scissors (small and large)
- Tweezers
- Needle (for splinter removal), safety pins
- Latex gloves
- Thermometer
- Tape - surgical adhesive
- Bandages - adhesive, elastic, gauze, triangular
- Absorbent cotton
- Sterile pads
- CPR barrier device
- Eye pad
- Cold pack, heat pack
- Selection of pain relievers, anti-inflammatory: Aspirin, Tylenol, Ibuprofen
- Seasickness remedies – pills, suppositories, bands, patches
- Laxative - pills and suppositories
- Diarrhea medicine
- Antacid
- Poisoning emergency kit - Ipecac syrup (see note below), activated liquid charcoal
- Astringent wet dressing
- Antiseptic
- Alcohol wipes
- Anesthetic - surface, topical spray (sunburn etc.)
- Burn pads/ointment
- Toothache drops (oil of cloves)
- Sun block
- Eye lotion (saline solution) and plastic eyecup
- Petroleum jelly
- Decongestant
- Calamine lotion
- Antihistamine
- Sunburn cream/ointment
- Antibiotic cream

Note: Ipecac syrup, used to induce vomiting, is a toxic substance and should only be used under the direction of a physician or poison control centre.

8. Know the spare engine parts one might deem prudent for a one-week cruise.

The following engine spares should be on board for a one-week cruise:

- Fuel filter
- Oil Filter
- Engine oil
- Drive belts
- Engine coolant
- Tapes (electrical, sail repair, rigging, duct tape, silicon)
- Electrical wire
- Fuses
- Stainless wire
- Hose clamps
- Spare hose (various sizes)
- Water pump hose
- Water pump impeller
- Water strainer
- Fuel/water separator

9. Know the minimum set of tools required for a one-week cruise.

Tools to carry for a one-week cruise in coastal or inland waters would include:

- Wrench set (metric & imperial)
- Adjustable wrenches
- Allan wrenches (metric & imperial)
- Socket set (metric & imperial)
- Cordless drill with charger & bits
- Screwdriver(s) and assorted bits
- Hammer
- Hacksaw and spare blades
- Bolt cutters
- Box cutter
- Wire cutters, wire stripper
- Locking vice grips
- Pliers (needle nose, electrical, channel lock, standard)

10. Describe the general procedures to be followed and the documents required for entering a country after leaving another country, and the current procedures for marine travel between Canada and the USA.

*** Please note that these procedures are government regulations and are subject to change at any time. For the most up-to-date information, check with the relevant local authorities before you depart.*

At the minimum you will need a passport for each member of the crew, the ship's papers and, if chartering, permission from the owner/charter company to take the boat across an international border.

ENTERING THE UNITED STATES

The following information is based on: [CBP Pleasure Boat Reporting Requirements, Oct. 2018](#).

Annual User Fee Program

The United States has a user fee program in effect for pleasure vessels over 30 feet. The annual fee is \$28.84 USD (in 2019). A decal is provided as proof of payment. Payment is required for the vessel at or before the time of the first arrival for each calendar year. Decals may be purchased at: <https://dtops.cbp.dhs.gov>.

Regular Reporting Procedures

Boaters must report in-person for inspection to the nearest open marine Port of Entry during the established hours for the port. If arrival occurs after normal business hours of the port, the boaters must call a locally designated number to advise of their arrival. Only the skipper may go ashore to report the arrival to CBP in person. All crew and passengers must stay on the vessel until permission is received from the clearing officer. No baggage or merchandise may be removed or loaded until the report of arrival is made and release is granted by a CBP officer. There may be other policies in effect at certain Ports of Entry. The skipper and crew should take direction from the appropriate authority.

Alternative Inspection Systems (AIS)

Alternative Inspection Systems (AIS) satisfy the boat operator's legal requirement to report for face-to-face inspection. There are three exceptions to the face-to-face inspection at a designated reporting location: using the CBP ROAM App available on Android and Apple devices, NEXUS, and Canadian Border Boat Landing Permit (I-68). Visit the U.S. Customs and Border Protection website for more information.

Information and Documentation Needed to Report

All Vessel masters must have the following information available:

For the Vessel:

- Name of the boat and/or registration number, length and flag;
- Make, model, year and colour of boat;
- Arrival date and time;
- Home port and current location;
- Return contact number;
- Customs and Border Protection (CBP) User fee Decal Number (for private vessels 30 feet or more in length).

If the vessel is registered, have the Blue book (Canadian registration document) on the vessel in possession of the skipper. Licensed vessels will have a certificate of license that should be on the vessel. In the case of charter vessels, the skipper should have a copy of the Charter Agreement. It may be prudent to make several copies of registration or licenses and have them notarized.

Proof of insurance may be helpful to have with the "ship's papers". Also check with your provider to establish your coverage and liability position when you are in foreign waters.

For the Skipper, Crew and Passengers

- Name, date of birth and citizenship of all persons on board (including passport number);
- Trusted Traveler document info readily available (i.e. I-68, Nexus).

The United States requires all Canadians entering the country to produce a passport or other approved secure document when entering the U.S. Visit www.cbp.gov and www.cbsa.gc.ca for a list of compliant documentation for travel to, from or through the United States.

The skipper is required to make sure that all crew and passengers have their current and valid documents. The skipper will secure all these documents and present them to Customs upon entry to the U.S.

If you are a citizen of another country other than Canada, you may be required to have a visa to enter the U.S. Check with the U.S consular service to determine your eligibility. Skippers should be aware of any reasons why a crew member may be denied access to the U.S. Remember the U.S. now requires some people to declare their place of birth and will fingerprint and photograph individuals.

As a skipper, ask your crew for information that may preclude their entry to the U.S. An old conviction for a minor drug offense for example may show up on the check in. The person may be denied entry.

If you have children on board the vessel that are not your own or you are not the legal guardian, make sure you have written permission to have them in your care. Single parents without official custody may be subject to scrutiny. The border agents from both countries have a strong mandate to watch for missing or exploited children.

If anyone is taking prescription medicine, make sure they have a prescription for it. Some medication that is legal in Canada may not be in the U.S. It is not wise to carry firearms on your vessel. If you are, make sure you have the appropriate registration certificates. Also insure that the weapon(s) are properly secured, and ammunition inventoried and accounted for.

The United States is very security conscious and Security and Customs Regulations are constantly updated and changed. Keep yourself informed.

It may be a good idea to have a Documentation Check List:

- Proof of Ownership (Blue book);
- Vessel License;
- Charter Contract;
- Crew Documents (Passports, Visas);
- Pre-approved I-68 or NEXUS member cards;
- Special Letters of Permission (Children);
- Medical Prescriptions;
- Pardons (legal);
- Special Permits (firearms).

RETURNING TO CANADA

The following information is based on: [Reporting Requirements for Private Boaters](#), July 2018.

As master of the recreational boat, the skipper is required to report directly in-person at one of ten Direct Reporting Sites for Marine Private Vessels (DRS/M) or go to a designated Telephone Reporting Site-Marine (TRS/M) and call the telephone reporting centre (TRC) at 1-888-226-7277. To find designated telephone reporting marine sites in your area, call 1-888-226-7277.

No one except the skipper may leave the boat until the CBSA gives authorization. The skipper is required to provide the information concerning the vessel and the crew as described below.

For the Vessel

Proof of ownership (Blue book) or a vessel license certificate will be necessary. In the case of "charter" vessels, have a copy of the valid charter contract. Borrowed boats will require owner permission preferably in writing.

For the Crew

- Name, date of birth and citizenship for every person on the boat;
- Photo identification and proof of citizenship documents (passport, enhanced driver's license, Nexus, FAST card and visa information) of passengers;
- The destination, purpose of trip and length of stay in Canada for each passenger who is a non-resident of Canada;
- The length of absence for each passenger who is a returning resident of Canada;
- Declare all goods being imported, including firearms and weapons;
- Report all currency and monetary instruments of a value equal to or greater than CAN\$10,000;
- For returning residents of Canada, declare all repairs or modifications made to goods, including the boat, while these items were outside Canada;

If no verification is necessary, the border services officer at the TRC will provide a report number to the master. The receipt of this report number will constitute release unless an officer on-site otherwise instructs the master.

If verification is to be conducted, the border services officer at the TRC will advise the master to remain at the site and to ensure that all goods and passengers remain on board until the verification team arrives. The verification team will conduct the verification and provide the master with a report number.

Other Considerations

The Canada Border Services Agency has a pamphlet called ***I Declare***. It is a very comprehensive guide for Canadians returning to Canada from abroad. It is available at www.cbsa-asfc.gc.ca or from any Border Services Agency Office. The documentation required to return to Canada is much the same as you needed to enter the U.S.

It is possible to register your vessel with the CANPASS program that will allow you to declare your entry into Canada by telephone. A credit card number is kept on file and any duties or taxes due on purchases in the U.S. are billed. Contact Canada Customs for more information.

Pre-registration of travel information

To help ensure minimal wait times for private boat owners/operators reporting their entry into Canada using the CBSA Telephone Reporting Centre (TRC), you can pre-register your personal and travel document information in advance. You must provide the following information for each individual on the boat:

Full legal name, Date of birth, Travel document number, type and expiry date

E-mail your information to TRC_PreRegistration_InscriptionPréalable_CRT@cbsa-asfc.gc.ca. The CBSA will enter your information into their system within 24 hours of receipt. You must still use the regular reporting methods to report your entry.

Section II: Living Afloat & Boat Systems

11. Discuss galley procedures in order to minimize the danger of fire, scalding or other galley accidents.

Cooking while underway allows you to prepare and serve hot meals when the vessel is moving or allows you to have a meal ready as soon as you reach port. When cooking underway, at anchor or at dock, vessel motion and the space restrictions in the vessel galley pose unique challenges to the chef.

When cooking aboard, the results of cooking fuel combustion produces CO (carbon monoxide) and water vapour. CO is an odourless but poisonous gas with side effects somewhat similar to motion sickness. When cooking aboard, ensure that there is adequate ventilation to avoid CO buildup.

The primary hazard is the possibility of scalding from hot liquids. Follow these safety precautions:

- Use a safety belt and bar to prevent you from losing your balance;
- Wear a rubber apron or foul weather gear with pants over boots so that any spill will not scald you;
- Warn the cook of large waves or sailing manoeuvres;
- Pour hot liquids over the sink so that any spills are contained;
- Minimize the chance of a spill by only filling pots half way and whenever possible using high-sided pots;
- Use pot clamps and be sure the stove gimbals are unlocked so that it can swing and stay level;
- Do not stand down slope of the stove.

Above all, do not use any white gas stoves (such as Coleman® or naphtha stoves) as the fumes are very explosive.

Every stove has its own safety rules that you must follow. If you don't know how to operate a stove, ask the skipper or consult the operations manual.



Stove with gimbals, safety bar and pot clamps.

12. Describe the common cooking systems (stoves and fuels) with respect to safe procedures for the operation of appliances, including safety checks, igniting appliances and system shut down, convenience, speed of cooking and costs.

Alcohol stoves – There are two types of alcohol stoves, pressure and wick style. The pressure stove has a tank that contains the alcohol and is pressurized with a pump built into the stove. Pressure alcohol stoves typically require the burner to be primed (pre-heated ensuring that the alcohol fuel is vaporized when emitted from the burner). Pure alcohol stove fuel is required to ensure proper operation of these pressure style burners. Wick style burners work like a lantern, with the wick placed in a small fuel reservoir. Alcohol is an expensive, slow cooking fuel that burns with a clear blue flame that is hard to see in bright sunlight. It may flare up from improper operation. Keep flammable materials away from stove, don't re-prime hot burners and don't overfill the primer cup. Have a pot or spray bottle of water ready when lighting stove. There is little risk of explosion of vaporized fuel.

Kerosene stoves – Similar in operation to a pressure alcohol stove except you use alcohol to prime the burner. It is fast cooking but requires priming to start. Kerosene is inexpensive and widely available. Explosive vapors are not normally present but improper use can result in a sooty flame in the cabin.

Diesel stoves – The stoves are heavy and are mounted rigidly so they usually have fixed rails to contain the pots. Because of their mass they are slow to heat up so are not practical to simply heat a kettle. They produce a gentle heat that serves as a cabin heater for a live aboard vessel. Requires a stovepipe. One advantage is there is no need for a second fuel on board.

Compressed natural gas (C.N.G.) – C.N.G is lighter than air and its vapour will normally dissipate. These systems are fast cooking but use large heavy cylinders (which look like elongated scuba tanks) that are expensive. In some areas it may not be convenient to exchange an empty cylinder.

Electric stoves– These stoves require a generator or shore power for operation. They are common on commercial vessels but not usually found on recreational vessels.

Propane stoves – Propane stoves are relatively fast cooking and use fuel that is readily available. The danger with propane is that it is heavier than air, and thus any leaks could collect in the bilge, presenting an explosion hazard. To minimize this risk, propane tanks must be stored in a locker that is sealed off from the vessel interior and has an overboard vent to let any leaking propane drain overboard. Propane has a distinctive smell added to it (rotten eggs) to alert you of any leaks. To light the stove, turn on the tank valve, turn on the remote-controlled solenoid valve, which allows propane to flow to the stove, apply a flame to the burner and open the valve. To shut off the stove turn off the solenoid valve to burn off pressure in the line, then close stove valve once lines are drained. Turn off the propane tank valve and leave it off when the stove is not in use. Vessels using propane should install and use fume detectors. Disposable propane cylinders must not be stored inside the hull due to the possibility of leakage.

13. Discuss common types of cabin heaters with respect to safety, convenience and cost.

Marine appliance manufacturers offer a variety of cabin heater types designed to keep the cabin and crew warm, dry and cozy even when conditions outside are challenging. When properly installed and maintained, cabin heaters are a blessing during the cold, wet days on the water. Safety issues that arise from improperly installed or faulty cabin heaters include:

- onboard fire;
- oxygen depletion;
- carbon monoxide exposure;
- excess cabin moisture contributing to mould and mildew.

When any appliance operates with an open flame, oxygen is consumed and combustion exhaust consisting of carbon dioxide, water vapour and other air pollutants are produced. If there is incomplete combustion of hydrocarbon fuels such as propane, kerosene, gasoline, diesel or wood due to a faulty or poorly maintained heater, or if ventilation is inadequate, carbon monoxide is also produced. Make sure when using any hydrocarbon-fueled appliance that the area is well ventilated to prevent oxygen depletion in the cabin and to vent any exhaust gases outside. An airtight heated cabin is an invitation to disaster. Be alert for any symptoms of carbon monoxide poisoning. It is a deadly gas that you can't see, smell or taste. Too many boaters have succumbed peacefully in their warm, comfy bunks after leaving their cabin heater on all night.

With respect to condensation, heaters can help maintain cabin moisture at appropriate levels. Heat produced by electricity and forced-air provide a dry heat, compared to heat produced by liquid fuels (e.g. kerosene, alcohol) that release water vapour.

The common types of cabin heaters may be grouped into: liquid and solid-fueled bulkhead heaters, catalytic heaters, electric heaters, diesel-fueled forced hot air and water (hydronic). These types of heaters are discussed below.

Liquid and Solid-Fueled Bulkhead Heaters – These moderate price, traditional fireplaces burn a wide variety of low-cost, readily available fuels including diesel, kerosene, propane, charcoal and wood (driftwood can be used, but may shorten the lifespan of the heater due to the salt). The heaters are simple in construction and operation, and create a nice ambiance if the open flame is visible. As there is no thermostat control, regulating heat output requires attention as the units can get quite hot. A fan is required to circulate the dry convection heat and a flue to vent combustion exhaust. With the exception of propane heaters, it can get smoky or sooty in the cabin if wind swirls the exhaust back through a mandatory open hatch or port. Also, the smoke can stain the sails or topside over time. Routine cleaning is necessary to prevent soot build-up. Regularly check the appliance and its surrounding surfaces for signs of heat damage and fuel leaks, and its flue and flue terminal for blockages, damage or signs of escaping exhaust gases into the cabin. Their convenience (they will burn a range of fuels) is balanced by the inconvenience of fuel storage and requirement for a chimney and the need to dispose of ash.

Catalytic Heaters – With the aid of a platinum catalyst, these appliances burn efficiently at a low combustion temperature without an open flame. The thermostat-controlled units are not a

big drain on the house batteries and can be fueled by propane, butane or less readily available CNG. A propane catalytic heater costs less than a liquid-fueled heater, but more than a solid-fueled one. The appliance heats the cabin area by emitting sun-like radiant heat that first warms people and objects, which in turn heat the air. Catalytic heaters supposedly produce less carbon monoxide than flame combustion heaters due to the lower combustion temperature. However, the level of carbon monoxide produced increases dramatically when the oxygen level in the living space is reduced. Proper venting of exhaust gases and a fresh supply of outside air are essential to avoid asphyxiation and condensation in the cabin. Unvented portable catalytic heaters (e.g. camp heaters) should not be used on board because of the venting issue and the potential fire hazard especially while underway.

Electric Heaters – Thermostat-controlled ceramic space heaters are safe, inexpensive and convenient to use. They require no exhaust venting and do not add to cabin humidity. Unfortunately, they require a steady source of AC power from shore or a generator. They are impractical to use with an inverter as a massive battery bank would be needed. Safety features should include an overheat protection device and automatic tip-over switch. Make sure the vessel's electrical system has plenty of fuses and breakers if you are also running a water heater, microwave, TV or other appliances designed for use ashore.

Diesel-Fueled Forced Hot Air and Water (Hydronic) Heaters – Properly installed, these mini-furnaces are safe, convenient and efficient to operate. They consume very little fuel, but do draw on the house battery for ignition and to operate the fuel pump and blowers. Controlled by a central thermostat, combustion air from outside the vessel and diesel fuel from the engine tank ignite in a sealed heat exchanger. The exhaust gases are safely vented outside the vessel. Air, water or coolant is then drawn over the heat exchanger and distributed evenly to all areas of the boat via air ducts or hoses. Fans or radiators provide a warm, dry heat to every nook and cranny including lockers and heads. The hot water heating system uses small diameter pipe for distribution and can assist in providing hot water for the shower and galley. The major concern with the hot air system is that the ducting is relatively large and takes up a significant amount of space. These installations are customized and therefore very expensive.

14. Describe the principle elements of the 120V and 12V vessel systems, their use, and considerations for proper battery management.

Most modern cruising vessels have two kinds of electrical circuit systems: direct current (DC) and alternating current (AC). There are a few concerns regarding electrical systems on a vessel. Current in both AC and DC power systems ***is potentially lethal, so safety is of the utmost importance when dealing with AC and DC circuits.***

DC System

The DC system delivers 12 volts and is supplied by the ship's batteries. It is used to start the engine and run all the equipment designed to operate on DC power including pumps, cabin lights, navigation instruments, VHF radio, etc. Most boats today are equipped with two or more batteries connected to a selector switch that allows them to be charged simultaneously, but used independently, a starter battery solely for starting the engine and one- or two-house batteries for all other electrical devices.

If your vessel is fitted with a four-position (OFF, 1, BOTH, and 2) battery selector, never turn the switch to the "OFF" position while the engine is running. Turning the switch to "OFF" while the engine is running can result in the alternator self-destructing. Put the battery to "BOTH" only if each battery does not have enough power to start the engine. Refer to the boat operating manual for specific directions pertaining to changing any switch settings while you are aboard.

When charging your batteries, think of each battery as a fuel tank. As long as you keep them topped up (charged), the system should run well. A fully charged battery is 12.6V at rest and between 13.5-14.5V with a charger. A fully discharged battery is 11.5V. The main battery charging sources are an engine-driven alternator or when plugged into shore power, an AC-driven battery charger. Charging systems may include solar panels or a wind generator equipped with charging controllers. An onboard generator may also be used to charge batteries.

A boat with improper wiring or faulty grounding might be leaking DC electrical current into the surrounding water. This can cause the electrolytic corrosion of metal parts of the boat in contact with the water and rapid depletion of sacrificial anodes.

AC System

AC is the same 120V current that is used in your home. It is available by means of an onboard diesel generator or by connecting a shore power cord from your boat to a receptacle on the dock. Many cruising boats today have installed a device called an inverter that can take the 12V DC from a vessel's house battery bank and change it into AC to power electronics and appliances intended for onshore use such as flat screen TVs, computers, air conditioners and microwaves. Be aware, an inverter will drain your batteries very rapidly if used on a regular basis.

When connecting to shore power at an unfamiliar marina it is possible that the hot and neutral wires may be reversed at the outlet. A warning light on board marked "reverse polarity" warns of this condition. If this occurs, disconnect the shore power immediately.

A more insidious problem is a shock hazard for a swimmer in the water. Several fatalities have been reported for swimmers near boats connected to shore power. Having an Electrical Leakage Circuit Interrupter or Ground Fault Circuit Interrupter (ELCI or GFCI) installed on board can prevent these concerns by detecting any possible stray current and shutting down the shore power entering the boat. A ground fault isolator may be installed which will protect your vessel from stray current generated by other vessels. Stray current may also be generated from faults in marina wiring systems. It is recommended that you should avoid entering the water in marinas.

Failure to maintain the shore power cord is the single largest cause of problems with shore power systems. The power cord ends are exposed to fresh and/or salt water and over time suffer from corrosion and general wear. If you have a lot of equipment turned on and the power cord is more than slightly warm at the boat or dock connectors, suspect a problem and replace or service the connectors.

When connecting to shore power, connect the shore power end of the cord last and disconnect it first. This prevents you from walking around the vessel carrying a live plug and, should you drop the plug into the water, will not generate damaging current. Never drop an energized cord in the water!

One last tip, before disconnecting shore power, make sure all power switches are turned off before switching off the boat's main breaker. This will avoid arcing. Then switch off the dock breaker before disconnecting the power cord to prevent getting electrocuted and damaging the contacts. **The arcing that will occur from unplugging a live cable will eventually burn the contacts inside the plugs and cause failure, as well as rendering the cable unsafe due to fire hazard. Inspect the plug ends for discolouration and distortion of the insulation around the pins and sockets.**

15. Describe refrigeration system types and state two ways to conserve power when a vessel is equipped with an electric refrigeration system.

Refrigeration systems on board vessels use either an evaporator plate or a holding plate in the icebox space. They may be configured as a standalone system (you just connect them to power like your home refrigerator) or may be split into separate components with the compressor system located outside of the icebox. In some installations the compressor is driven by a belt connected directly to the engine. For these systems, the engine must be running for the fridge to be cooling.

An evaporator plate refrigeration unit (also known as a constant-cycling DC refrigerator) operates the same as your fridge at home. The temperature is controlled by a thermostat in the icebox and every time the temperature rises above the temperature setting, the compressor switches on until the icebox is cooled down, then the unit switches off. This constant cycling several times an hour needs a constant supply of DC battery power. Some evaporator plate units can get cold enough to make ice. They are available as a horizontal, vertical or rolled plate and are relatively inexpensive.



Evaporator plate refrigerator.

A holding plate refrigeration unit works just like a large block of ice. When the compressor runs, refrigerant passes through a coil that freezes a solution within the holding plate. Once the holding plate is drawn down to -4°C for the fridge or -18°C for the freezer, it can stay cold for long periods thus reducing the drain on the battery bank. The refrigerator may only need to be turned on once or twice a day to coincide with docking and attaching to shore power or running the engine. Holding plate units are more expensive and take up precious space compared to evaporator plates.



Hybrid Refrigerator Unit.

A hybrid unit combines the capacity of a constant cycling unit with the efficiency of a smaller holding plate.

Regardless of refrigeration system, it will certainly be one of the largest power consumers on board. Running a fridge for 16 hours/day can consume 100-amp hours. To put this in perspective, it will take a typical charger or alternator 3-4 hours to recharge the battery. That is not a problem if you are docking and hooking up to shore power nightly or motoring extensively. But let's say you prefer to anchor nightly and sail when every opportunity presents itself. Here are the ways to conserve power with an electric refrigerator system:

- Fill the fridge and keep it full. A full fridge stays cold longer;
- Minimize opening and leaving the lid or door open for extensive periods - organize your fridge contents and know what you need and where it is before opening;
- Place a thermal cover on the inside top to minimize the loss of cold air;
- Pre-freeze food and water before the journey;
- Run fridge when operating the vessel under power and charging the batteries;
- Add ice, preferably blocks.

16. Describe water distribution systems with multiple tanks and various styles of pumps.

A typical onboard water distribution system consists of one or more water tanks. Recreational vessels are commonly fitted with rigid water tanks manufactured from polyethylene or metal. With two tanks fitted they may be positioned fore and aft (or port and starboard) and connected by tubing to a valve or manifold allowing the crew to control which tank to draw from to maintain boat balance or trim. As a rule of thumb, draw from one tank at a time so that you have a backup if one happens to spring a leak or become contaminated. If fore and aft tanks are installed, start with the forward tank to lighten the bow. Before departing, know the water capacity of each tank for monitoring the consumption rate. Also, familiarize yourself with the location of each tank's on-deck fill hoses in case replenishing is necessary.

Two styles of pumps supply water to the faucets – electric and manual. An electric pump pressurizes the entire water distribution system and switches on when any faucet is opened and switches off once the faucet is closed and the pressure in the system is restored. If you see a small oval tank downstream of the water pump, it is an accumulator. The accumulator reduces the pump from running when a tap is opened and small quantity of water is used.

A manual pump operated by hand or foot controls the water flow to a single faucet. It eliminates the need to pressurize the entire water distribution system. Manual pumps conserve water better than electric pumps; an important consideration if water replenishment is a concern.



Fresh water distribution system.

Manual foot pumps may also be installed which deliver sea water directly to the sink. These pumps aid in water conservation, allowing initial washes to use seawater and only the final rinse to use fresh water.

You may also find a small, insulated hot water tank connected to the system. Water can be heated on board through AC shore power or when the engine is running. Boat hot water tanks are relatively small compared to home systems and will not satisfy the demands for showers, dish washing etc. without frequent reheating.

17. Describe the proper operating procedures for the head and holding tank. List the precautions necessary to prevent malfunction and identify issues relating to holding tank capacity.

Referred to as the “head”, the toilet is a necessary appointment on any modern cruising yacht. According to The Oxford Companion to Ships and the Sea the correct term is “heads”. It was the name given to the area forward of the forecabin and around the beak of old sailing ships that crew used as their lavatory. It was always referred to in the plural to indicate the weather and the lee sides. Crew was expected to use the lee side. Seawater over the bows would help keep the “heads” clean.

On a modern cruising yacht of today the head is usually well appointed with a sink, shower and a marine toilet. We are concerned here with the proper operation of the **Type III Marine Sanitation Device (MSD)** which includes a marine toilet and holding tank.

When inspecting the MSD, first check the plumbing and seacock locations. Look for the raw water intake seacock that provides seawater to the toilet. The toilet discharge line may go through a “Y-valve” to divert waste to a holding tank or directly overboard (if legally permitted) via a discharge through-hull. Alternatively, the toilet discharge line is plumbed to a holding tank and then directly to a deck pump-out fitting or directed via a “Y-valve” to the deck pump-out fitting or a discharge through-hull. Vessels operating in inland waters must not be configured to allow discharge of black water overboard.

If emptying overboard is permitted where you will be travelling, examine how the plumbing is set up. Holding tanks are positioned to be emptied overboard either by gravity alone, or with the assistance of a manual pump or electric macerator pump. A macerator pump breaks up the waste as it discharges. Macerator pumps have a notorious reputation of failing at the worst possible time. The usual culprit is the impeller; either it jams in the pump due to something not allowed being flushed down the toilet, or it burns up due to running the pump dry or continuously for more than 2 minutes at a time.



Plumbing and seacocks clearly labeled

The holding tank is used for the temporary collection and storage of effluent until it can be discharged at an approved pump-out facility or outside a designated no-discharge zone. The holding tank capacity for a typical cruising vessel may range from 45-90 L. Depending on the number of people on board and the availability of onshore toilet facilities, a holding tank may need to be emptied as frequently as every 1-3 days. When planning a weeklong trip, an attentive skipper will consider this issue in advance so as not to be in confined waters and harbours with a full holding tank, or worse, overflow the holding tank and plug the air vent!

The following sequence is typical for operating a manual marine toilet:

1. Open the raw water intake seacock;
2. Move the bowl selector lever to the "wet bowl" position;
3. Lift and lower the pump handle repeatedly to draw sufficient water into the bowl;
4. Move the bowl selector lever back to the "dry bowl" position;
5. SIT AND USE THE TOILET - Yes gentlemen, when at sea, sit to pee!
6. When finished, pump the bowl contents until mostly empty;
7. Move the bowl selector lever back to "wet bowl" position;
8. Pump several times to flush the toilet. If discharging overboard, continue pumping to clear the discharge line of effluent. If pumping into a holding tank, excessive pumping will cause more rapid accumulation of black water;
9. Move the bowl selector lever back to "dry bowl" position;
10. Pump to remove excess water in the bowl;
11. Close the raw water intake seacock to ensure boat safety.

Some boats are equipped with electric toilets. Read the instructions on proper use. Exercise caution when flushing these toilets to avoid pumping large volumes of water into the vessel holding tank.

Prudent skippers will have "Instructions for Use of Marine Toilet" prominently displayed in each head.

PRECAUTIONS TO PREVENT MALFUNCTION (A polite way to say "***DON'T PLUG THE TOILET***")

There comes a time in every sailor's life when he or she has to deal with a plugged toilet. It is an experience one does not want to repeat. The lesson learned will be unforgettable. ***Advise the crew of their responsibilities concerning the head!***

1. Nothing goes into the head that hasn't passed through the body;
2. Use a minimum amount of "marine type" toilet paper;
3. No paper towel, tissue, diapers, dental floss, finger nails or other material in the head that will plug the lines or jam the macerator pump;
4. Provide your female crew or guests with alternate disposal methods for hygiene products;
5. Parents monitor their children;
6. Pump lots of water through the system to clean the discharge lines;
7. Use the ashore facilities when accessible.

The single biggest complaint with MSDs is odors caused by anaerobic bacteria that break down raw sewage. Anaerobic bacteria thrive in an oxygen-free, raw sewage environment. By keeping the sewage discharge lines clean, not plugging the air vent by overfilling the holding tank and emptying the holding tank as frequently as possible, many of the odor and head problems will dissipate.

18. Identify boating environmental issues, with particular reference to responsible disposal of waste and management of pollutants.

Protecting our marine wildlife and ocean environment is a shared responsibility, and as skipper of your vessel, it is important to know and obey Canada's Regulations for the Prevention of Pollution from Ships and for Dangerous Chemicals. These regulations address the discharge of waste and disposal of toxic substances that have devastating effects on the marine habitat.

Untreated human and animal sewage discharged overboard in popular anchorages and marinas has resulted in shellfish closures, unpleasant swimming experiences and health risks. The Canada Shipping Act 2001 prohibits the discharge of untreated sewage within 3 miles of shore, and the Great Lakes and their tributaries are no-discharge zones. Boats fitted with a toilet must have either a holding tank (Type III MSD) to collect and store sewage for emptying at approved pump-out stations, or a marine sanitation device designed to receive and treat sewage on board and meet the standards set out in the regulations. To lessen your environmental impact, use shore side facilities whenever possible and avoid using bleach or harsh chemicals in the holding tank.

Disposal of garbage and other waste depends to a large extent on the facilities available ashore for the cruise intended. Garbage should be separated into biodegradables, burnables, plastics and recyclables. In remote areas with open waters and currents, chopped up biodegradables may have to go overboard. Also, in remote areas it may be necessary to burn burnables below the high tide mark. It is illegal to put plastics in the oceans of the world. Save plastics and recyclables for proper facilities along the way or take them home after the voyage.

Spilling fuel into the water is illegal. A small amount of fuel in the water is enough to harm or kill marine organisms over a very large surface area. To avoid spills, don't rush re-fueling and don't top up the tank. Place a "fuel saver" over the fuel vent to catch any overflow that exits the full tank. Have fuel absorbent materials on stand-by and never use soap to disperse fuel spills. It causes more harm to the environment and is illegal too.

Oil, fuel, antifreeze and transmission fluid are engine fluids that contaminate the bilge water waiting to be discharged overboard by the automatic bilge pump. This is a criminal offence. Use the bilge pumps only for removing uncontaminated water. If the bilge is contaminated, use towels or bilge cloths to absorb the fluid and then dispose of them correctly. To prevent bilge contamination, secure a drip tray or absorbent bilge cloth under the engine to catch any petroleum products. Keeping the engine well tuned and maintained is good for the air and water environment. Follow best and legal practices when changing and disposing engine fluids, filters, batteries, paints, solvents and detergents. Contact the Coast Guard to report all spills. More information on Marine pollution sources and regulations is available from Transport Canada.

19. Describe the safe operation of an anchor windlass, including appropriate vessel handling while using this equipment.

Cruising vessels today are often equipped with heavy ground tackle mechanically operated by a windlass. The windlass should be handled with care and treated with respect. Incorrect use could cause personal injury and damage to the vessel. Only crew who are completely familiar with the controls and proper use of the windlass should be allowed to assist in the anchoring operation.

Follow these tips for the safe operation of an anchor windlass:

1. Only operate the windlass when the engine is running;
2. Always shut off the windlass circuit breaker when not in use. Never attempt to resolve a windlass jam while the circuit breaker is on;
3. Always operate the windlass in view of the ground tackle. If there are dual controls for the windlass (e.g. helm and bow) make sure only one person operates the windlass;
4. Always close deck mounted footswitches when not in use to avoid accidental operation of the windlass;
5. Always wear proper footwear (that cover the feet) when working with the anchor, its rode and windlass;
6. Always ensure that limbs, fingers, long hair and clothing stay well clear of the anchor rode and windlass during operation. Never hold the anchor rode while the windlass is in operation;
7. Always take the load off the windlass once the anchor is set. If left under load, the constant wind and wave action could damage the rode and the windlass. There is also a risk that the clutch nut could come loose causing the boat to slip its mooring. Tie off the rode to a bow cleat or, if a chain only rode, use a chain stopper device. An alternative is to fashion a bridle with a snubber using a mooring line and a rolling hitch;
8. Always use the vessel's engine to assist anchor recovery by moving the boat very slowly forward to take the load off the anchor rode before operating the windlass. Do not use the windlass to pull the boat to the anchor. Take care not to damage the bow roller and hull by overriding the anchor chain during recovery. The windlass operator must also check that the chain piling in the chain locker does not foul the chain pipe and jam the underside of the windlass. If a jam looks likely, carefully knock down the chain pile before it's too late;
9. Always use the boat engine with a chain stopper taking the load to break an anchor loose. If the anchor is fouled, do not use the windlass to break it out;



Anchor windlass and ground tackle

10. Always haul in the last few feet preferably by hand or inched in judiciously by the controls to avoid damage to the bow roller and hull;
11. Always secure the anchor to its stowed position when underway. A safety line tied to the anchor, a pin through the bow roller and the anchor shank, or engaging the pawl in the gypsy are acceptable methods.

20. Differentiate between various sail handling systems and discuss handling and operational considerations of a particular combination of systems including furling systems (foresail, mainsail in mast, and mainsail in boom) and mainsail flaking systems.

Advancements in sail handling systems have changed the way we cruise today. We can sail more safely and easily on bigger boats with fewer crew. As boat size increases, so does the size of the sails. Flaking a mainsail less than 300 square feet is easy to manage and requires little in the way of a sail handling system. Similarly, bending on the genoa for a 9 metre daysailer is still manageable. But as the size and weight of a main and foresail increases, the need for a flaking or roller-furling system becomes almost essential. Each system has specific handling and operational considerations along with benefits and pitfalls.

MAINSAIL FLAKING SYSTEMS:

Lazy Jack System – This is the simplest flaking system which captures the mainsail as it is lowered or reefed to rest on the boom. A series of lazy jack legs (lines) on both sides of the main lead from high up on the mast down to the boom to form a cradle. The bottom legs can be cleated to adjust the system's tension. Lazy Jacks work particularly well with fully battened mainsails but care must be taken not to have the battens or leech catch between the lazy jack legs when hoisting or lowering the main.

Stack Pack System – This is the most complex flaking system. It integrates lazy jacks with a top opening mainsail cover that is attached to the boom. The fully battened sail drops into the sail cover which then is zipped up.

Dutchman Flaking System – This system uses the same principle as Roman shade blinds. It automatically flakes the main by sliding on two or three vertical control lines that are weaved side-to-side through cringles on the main from the foot of the sail to clamps on the topping lift. Modifications to the sail are required but the system eliminates any lines from catching the battens or leech when hoisting or flaking.



Lazy Jack Flaking System

ROLLER FURLING MAINSAIL HANDLING SYSTEMS

In general, furling mainsail systems are easy to use, can be furled to any sail size, and don't require flaking or a sail cover.

In-Mast Furling System – The mainsail passes through a slot in the aft end of the mast and is furled on a rod in the mast much like a foresail furling system. This can only accommodate a sail fitted with vertical battens. When the sail has no battens, the leech is cut concave and there is some compromise in sail shape and area. The furling line or sail can jam in the mast preventing the sail from being lowered if partly furled. When furling the main, keep some tension on the outhaul to ensure a tight sail wrap in the mast. Furling may be accomplished using a furling line that rolls onto a drum in the mast, or using a continuous line attached to a geared system located on the back of the mast. When setting (unfurling) the main (by tensioning the outhaul) keep some tension on the furling line to prevent an override and to keep the furled portion of the sail tightly wrapped.



In-mast furling system

Behind Mast Furling System – Similar to a foresail furling system for operation and handling considerations.

In-Boom Furling System – This system allows a mainsail to roll up completely inside the boom. In-boom furling can accommodate full battens and so the sail can be designed with a full leech. Storage in the boom keeps the weight of the stored sail low, as opposed to the mast furling units which raise the center of gravity. In the event of a jam the sail can be lowered and tied off around the boom. When furling the sail, keep some tension on the halyard to ensure a tight wrap. When raising the sail, keep some tension on the furling line to prevent an override. Because of their high price, in-boom furling systems are more commonly found on larger boats.

FORESAIL ROLLER FURLING/REEFING SYSTEMS

Roller furling foresails are common on production cruising boats because of their ease of handling and safety. Being able to deploy, reef and stow the foresail from the safety of the cockpit is a desirable feature. There are compromises in performance when sailing in light wind due to the heavier sail cloth weight selected to cover a wide range of conditions. In strong winds, when reefed, there is also a compromise in sail shape because furling generates a roll at the leading edge of the sail which disturbs air flow and the draft of the sail is concentrated into a smaller area. A flatter sail is desirable in heavy air. A roller furling foresail is set by easing the foresail furling line and hardening the leeward jib sheet. Some tension should be maintained on the furling line while setting the sail to prevent an override in the furling drum. When furling the foresail, keep light tension on the jib sheet to ensure a reasonably tight wrap around the foil. In heavy winds, the vessel may need to be sailed downwind while furling to reduce load on the sail and allow the sail to be completely furled.

Section III: Weather

21. Describe the effect of local heating and cooling of the land and water as related to wind and cloud formation.

Clouds come in many different types and shapes and reflect the weather conditions under which they were formed. The sailor can obtain an insight into weather activity by reading the direction and speed of movement of the different cloud types.

The earth's atmosphere is made of fixed proportions of oxygen, nitrogen and other gases as well as natural and industrial dusts and pollutants plus various amounts of water vapour. The amount of water vapour a given volume of air can contain is dependent on its temperature. The capacity to hold water vapour increases as the air becomes warmer and decreases as the air cools.

When a volume of air at one specific temperature has picked up as much water vapour as it can hold, it is said to be "saturated" and is at 100% relative humidity. If this air is cooled, some of its water vapour will condense into tiny water droplets, which suspended in the air, form clouds. This condensation occurs around minute dust particles which act as nuclei for the droplets. In the atmosphere, generally as the altitude increases, the temperature decreases. Therefore, a warm, rising body of air containing water vapour will at some altitude reach its dew point and form a cloud.

During periods of settled weather, the sun will be shining. As the sun shines on a coastal area the land mass will warm up more quickly than the water. This gives rise to a warm mass of moist air rising above the land. As this body of air rises, it will begin its cooling process and will finally condense around minute dust particles to form fair weather cumulus clouds.

These clouds are white, fluffy and generally have flat grey bottoms and are distributed along the coastal region at the same altitude. These clouds tend to form mid-morning to late morning. Cloud height (base to top) is usually less than the height of the base of the cloud above ground.

The rising column of air above the land causes an inflow of cooler air from above the water surface. This inflow is a sea breeze (named for where the wind comes from) or onshore wind and persists until late afternoon. At this time, with the decreasing height of the sun, the land mass begins to cool and the column of warm moist air above it ceases to rise. Without the rising column of air, cloud formation stalls and existing clouds dissipate.

As the sun falls below the horizon the land mass begins to cool at a greater rate than that of the water. The water now becomes warm relative to the land. Air begins to rise above the water and is replaced by the flow of air from the land in the form of a land or offshore breeze. The strength of this land breeze may, in some circumstances where the slope of the land is considerable, be augmented by a katabatic wind flowing down the slope.

The strength of the overnight land breeze is typically less than that of the sea breeze occurring during the day. Given the general westerly flow of air across our latitudes, sea breezes on west coasts are usually stronger than those on east coasts. These sea and land breezes are sometimes referred to as thermal winds, although this is an incorrect term. A thermal is a rising column of warm air that precedes the formation of clouds and is a precursor condition to the formation of these breezes.

22. Identify conditions likely to lead to fog.

Fog is essentially a cloud that has formed in the shallow layer of air next to the surface of the earth. Warm air can carry relatively large amounts of moisture. As warm air cools it loses the ability to carry moisture. Water precipitates out of the air and fog may form. Injecting moisture into cold air may also cause the formation of fog. Fog and mist are similar in formation. The term fog is used when visibility is 1 kilometre or less. Fog can be a serious hazard to safe navigation. There are several types of fog:

Advection Fog – Forms when warm, moist air moves over a relatively cold surface. Advection fog is a thick, heavy fog which doesn't dissipate during the day. This is the most common fog at sea, forming as warm air meets cold water.

Radiation Fog – Caused by the land cooling on a clear night, radiation fog is usually fairly 'thin' and patchy and disappears in the morning as the land heats up again. Clear skies, moist air, and light winds are the precursors to radiation fog.

Upslope Fog – Is caused by the air cooling as it moves up a slope. Not typically a hazard to sailors.

Steam Fog or 'Sea Smoke' – Evaporation fog or steam fog is formed when water vapour is added to air which is much colder; most commonly, when very cold air drifts across relatively warm water.

23. Describe the effect of wind against current.

On bodies of water with current, beware of a wind blowing against the direction of the current. This situation creates choppy waves (wave having a very abrupt shape). Not only are the waves steep but they are higher and closer together (smaller wavelength).

Boats usually have difficulty moving forward in such a wave regime. It is not uncommon for it to be impossible to take them head-on, and for the person at the helm to be forced to modify the course in order to approach them obliquely. Depending on the circumstances (type of boat and condition of the sea), it may be prudent to find an alternate route or to wait for the slack currents and / or a decrease in force wind before crossing these areas.

In addition to difficult progress, these waves put a strain on the hull and rigging.

The crew should be careful when moving around the boat.

By listening to the weather forecast you can predict such a wave regime and take appropriate action.

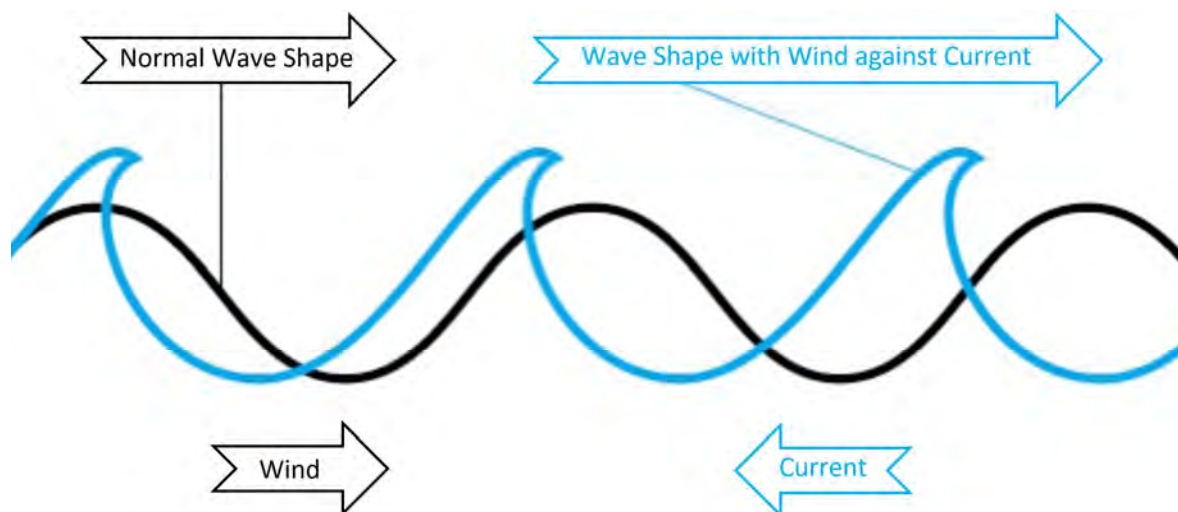

Section IV: Seamanship

24. Describe the complete actions to be taken for the following:

- | | |
|-----------------------------------|---|
| a) Springing a leak, | g) Fire, |
| b) Steering fails, | h) Propane leak, |
| c) Grounding, | i) Engine failure in an anchorage too crowded to permit safe sailing, |
| d) Fouling a propeller, | j) Engine failure in a busy channel, |
| e) Dragging anchor, | k) Engine cooling water fails to flow. |
| f) Collision with another vessel, | |

24 a) Springing a leak – Start pumping immediately and try to determine the source and extent of the problem. Make sure the crew are wearing PFD's. Consider sending a distress signal (if you are unable to control/manage the water ingress from the leak). Check all seacocks for failure, and use tapered softwood plugs if necessary. If the leak is due to holing of the hull, try to plug the hole from the inside with cushions or clothing. If the hole is large, try to slow the leak by covering the hole from the outside using a sail, tarp or blanket stretched across the damaged area.

24 b) Steering fails – Assess the situation and try to gain control of the boat as soon as possible. Consider anchoring if the water depth and other factors make this practical. Other possible control methods include:

- Using the emergency tiller if the link between the wheel and tiller is the problem.
- Steering with sail balance (hardening the main sail, while luffing the jib will cause the boat to head up, luffing the main sail while pulling in the jib will cause the boat to bear away).
- Towing an object (bucket, sail bag, spare anchor with fenders, etc.) behind the boat to act like a small sea anchor. Drag on one quarter will tend to steer the boat in that direction.
- Using the dinghy and outboard engine rafted either alongside or pushing the boat.

If you can't steer the boat well, your goal should be to get within easy range of a tow to either a dock or an anchorage.

24 c) Grounding – As opposed to 'running aground', grounding occurs when the boat is at anchor, resulting from an anchor dragging or a falling tide. Assess the situation and determine the cause of the grounding. Consult appropriate tide tables and determine whether the area will dry out. If so, prepare to shore up the boat if possible using anchors, lines, spinnaker pole, etc. If not possible, try to lean the vessel to a preferred side where it will rest on the ground as the area dries out. Try to place padding below the hull. Prepare the inside of the boat by securing all loose items (pay particular attention to the batteries and fuel tank!) and closing all windows and hatches. Monitor the situation as the area dries out and the boat refloats.

24 d) Fouling a propeller – The engine will likely stall. If it has not stalled shift into neutral or shut it down. Gain control of the boat either by anchoring, drifting alongside a dock, or by raising the sails. Try to determine what is fouling the propeller. Is it a sheet or dock line, or weeds, or is it a crab or lobster pot? Try to clear by pulling free, or manually reversing the prop shaft while trying to unwind the line. If that doesn't work, consider sending someone over the side to cut the line free. This person should be a strong swimmer and remain attached to the boat with a line. Take into account the risk of hypothermia or injury caused by wave action on the hull. If you are unable to free the line, sail to the nearest dock, or if that's not practical, arrange for a tow into port.

24 e) Dragging anchor – Immediately increase scope by letting out more rode and maintain an anchor watch to see if this has solved the problem. If it has not done so or you find that you are too close to other boats or the shore, you will have to weigh anchor and try to set the anchor again in the same location or in a better location. Alternatively, you can start the engine and motor slowly in forward to take strain off the anchor and/or set a secondary anchor or kedge. A last resort may be to put to sea.

24 f) Collision with another vessel – A proper lookout combined with appropriate manoeuvring is the best means of preventing collision. According to the International Regulations for the Prevention of Collisions, *every vessel shall use all available means appropriate to the prevailing conditions to determine if a risk of collision exists. If there is any doubt, such risks shall be deemed to exist.*

If you are involved in a collision with another vessel the first priority is the safety of all of the people involved. Quickly determine whether any of the crew on either vessel has been hurt. Treat with first aid accordingly.

Check your vessel for any damage that is serious enough to make the boat inoperable. Is the hull sound? Are you taking on water? Has the standing rigging been damaged in any way? Is the mast secure? Are there lines or debris in the water that could foul the propeller if the engine is started?

Exchange information with the skipper of the other boat. Find out as much as possible about the registration of the vessel, the contact information of the skipper and/or helmsman, and the names of the other people aboard the boat.

Write down your account of the collision. Include all the relevant facts as you remember them – the speed and heading of boats, the wind direction, the sea state, visibility, weather conditions, etc.

If there has been property damage, and the damage appears to be over \$1,000, or the seaworthiness of the vessel is affected, you are required by law to report the collision to the Coast Guard even if there are no injuries.

Finally, as with a road accident, don't admit responsibility for the collision. Both vessels have obligations to avoid collision. The authorities and insurance companies will assign responsibility soon enough.

24 g) Fire – Since the dawn of seafaring, a fire at sea has been one of a sailor’s worst nightmares. As with many other emergencies at sea, avoidance is the best strategy, and good, up-to-date safety equipment the best insurance.

The small fire extinguishers aboard most vessels fulfilling the minimum legal requirement will not allow you to fight anything but the very smallest fires. A small extinguisher will discharge in about eight seconds and larger hand-held extinguishers will not generate propellant for more than 20 seconds. Most experts recommend a minimum two-pound extinguisher as the smallest fire extinguisher to be effective against even a small fire.

Extinguishers are designed to deal with specific types of fires. Dry chemical extinguishers are frequently found on vessels because they will address most common types of fire. About once a month take each dry chemical extinguisher out of its bracket and give it a few hard shakes in an upside-down position to keep the contents loose.

	Paper, Ordinary Combustibles	Flammable Gases and Liquids	Electrical
Water	✓	✗	✗
Foam	✓	✓	✗
Dry Chemical (ABC)	✓	✓	✓
CO ₂	✗	✓	✓

Should you discover a fire, alert the crew and attempt to extinguish the blaze. If the fire is small and confined to the immediate area where it started, you may have a chance at stopping the blaze. Fight the fire by pointing the extinguisher at the base of the fire, squeezing the handle and sweeping from side to side.

If the fire is beyond your control, send a Mayday over the VHF while the radio is still accessible and prepare the crew to abandon the vessel if necessary. Prepare the dinghy as an emergency ‘life raft’.

Be aware that burning fibreglass produces noxious fumes that can be extremely hazardous if inhaled. Fibreglass fires are extremely hot.

Do not open an engine compartment to extinguish a fire. Engine compartments should be configured with a fire port – a small opening, normally covered, through which you may discharge a fire extinguisher. CO₂ extinguishers which leave no residue should be used to attack engine fires.

24 h) Propane leak – Propane is heavier than air and will flow into the lower portions of your boat. Propane is hard to remove and is highly explosive. The presence of propane may be detected by smell (odour is added to the gas) or by use of a propane sniffer. If you detect a propane leak, shut off the manual valve on the propane tank and evacuate the area immediately. Contact the Coast Guard or local fire department for assistance and instruction. If you are isolated from help, open all hatches and windows to vent the bilge. Lift all floorboards to help in venting. If you have a manual bilge pump located outside the cabin, pump it for 15 minutes before re-assessing. Another option is to use a bucket and start “bailing” to scoop the air out of the cabin. DO NOT activate switches that may cause a spark.

24 i) Engine failure in an anchorage too crowded to permit safe sailing – Assess your location in relation to hazards. Set sail, drop anchor or raft alongside another anchored boat as conditions dictate. Have the crew ready with fenders, and alert other boats to your predicament so they are ready to provide assistance if necessary.

24 j) Engine failure in a busy channel – Gain control of your vessel. Use your momentum, the wind or the current to assist in gaining control. Drop the anchor quickly if possible and in a location that will not obstruct traffic. Assess the situation and the safest action to be taken. Have lines and fenders ready. Arrange for a tow if unable to safely sail out of the congested area.

24 k) Engine cooling water fails to flow – If there is no cooling water flowing, or the overheat alarm is sounding, serious damage to the engine will be done if it continues to run. Quickly assess where you are, and as soon as possible shut down the engine. Sail, anchor, heave to or dock under sail.

Visually check to ensure that the raw water through-hull is open and that the strainer does not appear to be clogged. After a short wait, restart the engine and monitor carefully. If the cooling water still isn't flowing, check the cooling system (seacock, hoses, water pump impeller, belts, thermostat, and coolant level).

To check the cooling system, first close the raw water intake through-hull. Disassemble and clean the raw water strainer. With the strainer open, slowly opening the seacock will allow you to determine if the water is getting in through the seacock to the filter. If that's not the problem, you can take the hose off the far side of the impeller (the output side of the pump) and start the engine. If water isn't flowing on the heat exchanger side of the water pump impeller, that means the pump and/or impeller are likely the problem and need to be replaced. If you can't fix the problem, try to sail to the nearest anchorage or marina, or arrange a tow.

WARNING - Do not continue to run an engine without raw cooling water flowing, even though you may have let the engine cool completely and now think you can run it for 5 minutes safely. Raw cooling water not only cools the engine, but it also is used to cool the exhaust gases and exhaust pipe. Exhaust pipes have to run inside the boat from the engine to the outside and are often made of rubber hose due to vibration and heat risks. If you run the engine without cooling water the rubber hose may burn, and serious damage can occur. A failed exhaust pipe is also a source of water ingress and boat flooding risk.

25. Describe in detail two methods of getting a crew overboard back aboard.

25 i) Triangle Method – Since 1992 the SAIL CANADA has supported the Reach/Tack/Reach Triangle Method of crew overboard as the primary return method. It is taught in the Basic Cruising course and practiced at subsequent levels of the Cruising Standards. It is reliable, efficient and effective, and has proven practical for most sailboats in a wide range of wind and sea conditions.

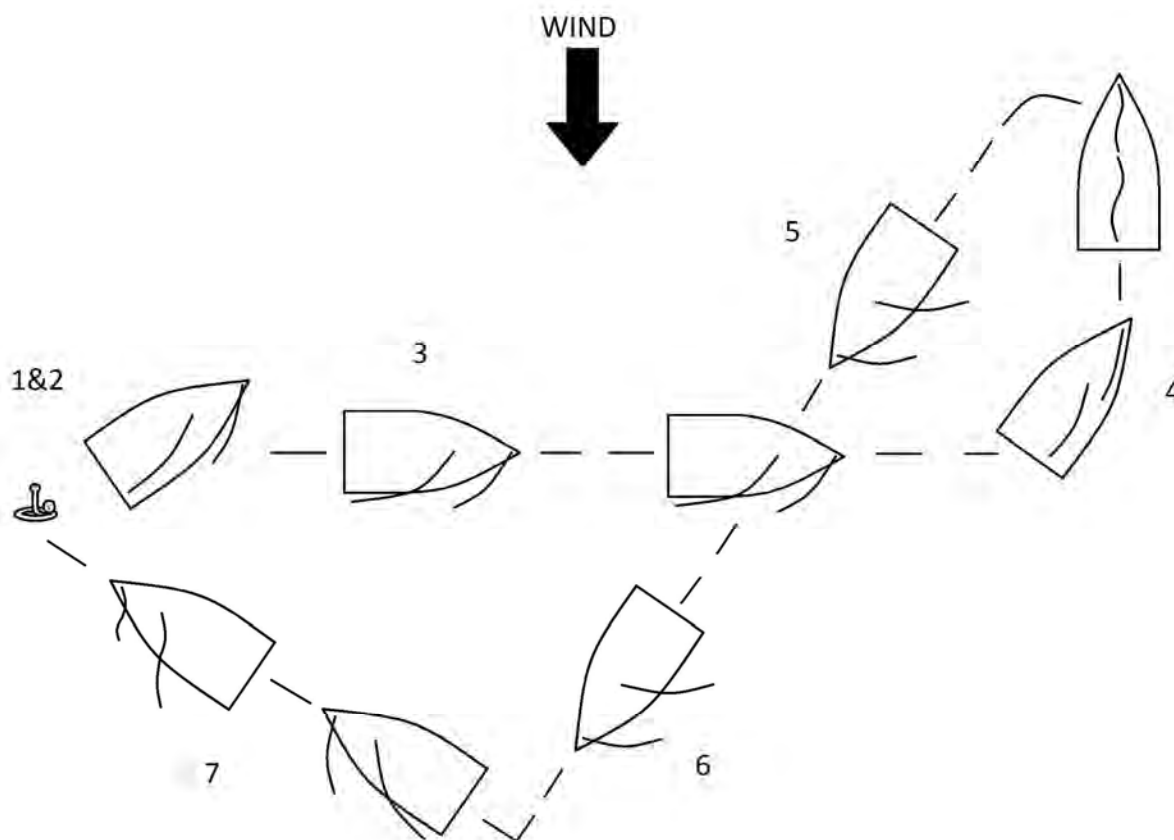

Triangle Method.

1. The spotter alerts all on board by shouting "CREW OVERBOARD!"
2. Buoyant objects are thrown to the crew overboard (COB). The spotter shouts "ARE YOU OK?" If the COB is all right he or she should signal this by raising one arm and placing hand on head, and by a verbal response.
3. Upon hearing the alert the helm immediately steers onto a beam reach on the same tack and commands, "EASE SHEETS FOR A BEAM REACH" (or "HARDEN SHEETS FOR A BEAM REACH if the boat was sailing downwind at the time the COB fell overboard). The helm then confirms the identity of the spotter. A beam reach is chosen because a reciprocal of this course brings the boat back close to the COB. The boat is sailed on a beam reach no

further away from the COB than is necessary to effect the maneuver, about 6-8 boat lengths depending on the vessel.

4. The helm commands "READY ABOUT. HARDEN SHEETS. HELMS-ALEE". As the boat heads up into the tack the crew hardens the sheets to assist the boat in making the tack. In heavy seas, if the sheets are not pulled in as the boat heads up into the tack from a beam reach, the boat may not maintain sufficient speed for the bow to round onto the new tack.
5. After the bow passes through the eye of the wind, the helm commands "BEARING AWAY, EASE SHEETS FOR A BROAD REACH."
6. The boat is sailed on a broad reach, its speed controlled by the trimmer(s); easing or hardening the sheets under the direction of the skipper/helm, until the boat is in a position where it can turn to approach the COB on a close reach. The crew readies the heaving line on the windward side.
7. The boat heads up sharply onto a close reach. The turn is sharp because, as the boat slows near the COB, it will have little steerage and may not be able to turn to windward if necessary. The foresail sheet is completely eased to keep the foresail luffing and approach speed is controlled by easing / hardening the mainsheet in order to arrive with the COB on the windward side at a speed of less than one knot. Both sheets must be completely eased by the time the boat arrives alongside the COB. Without drive the boat will not sail but will remain in place long enough for the heaving line to be thrown and the COB secured to the side of the boat. An approach to the COB with the victim on the leeward side may be the more desirable alternative in situations where the victim is disabled, unconscious or unable to assist in their recovery.
8. The COB must be secured to the side of the boat so he or she cannot drift away while preparations are being made for recovery of the COB. To minimize hypothermia the COB is pulled out of the water as far as possible when being secured.

Notes: In COB return and recovery situations with limited crew, there is no need to focus on sail trim prior to the close reach approach phase. Keeping a spotter focused on the victim should take precedence over all other activities. On vessels with large foresails set, reefing or completely furling the foresail prior to or during the close reach approach may provide the ability to appropriately manage vessel speed of approach and orientation. Furling the foresail and hardening the mainsheet during the recovery stage will reduce drift / leeway and provide a safer working platform for the crew involved in the recovery.

25 ii) Quick Stop Methods – For many of offshore cruisers a Quick Stop method is the preferred method of returning the vessel to the victim. These methods work well with limited crew and require focus on sail trim only at specific points in the maneuver. The Quick Stop's main advantage is in keeping the vessel very close to the COB. These methods work well whenever sailing single handed or without competent crew.

Quick Stop: Circle

This maneuver may be initiated from any point of sail but works best when sailing upwind.

1. The spotter alerts all aboard by shouting "CREW OVERBOARD!"
2. Buoyant objects are thrown to the COB. The spotter shouts "ARE YOU OK?" If the COB is all right he or she should signal this by raising one arm and placing hand on head, and by a verbal response. A Lifesling, if available, or life ring with attached floating line, may be deployed at this time.
3. Upon hearing the alert, the helm confirms the identity of the spotter and steers to a close-hauled course on the same tack and commands "HARDEN SHEETS FOR CLOSE HAUL".
4. The boat is sailed upwind 1 to 2 boat lengths until it can turn through head to wind, leaving the foresail backed and reach across to windward of the COB. Sheets are left as they were prior to tacking.
5. The boat sails on a beam reach to windward of the COB. When past the COB the boat bears away to a broad reach, then a run. Sheets remain hardened.
6. During this downwind leg, the vessel gybes. The main and foresail sheets remain hardened. During this leg the foresail may be furled.
7. When the boat reaches a position where it can approach the COB on a close reach, mainsail and foresail are eased and helm turns the vessel to head towards the victim. Pickup may be on either windward or leeward side, as appropriate for the situation.

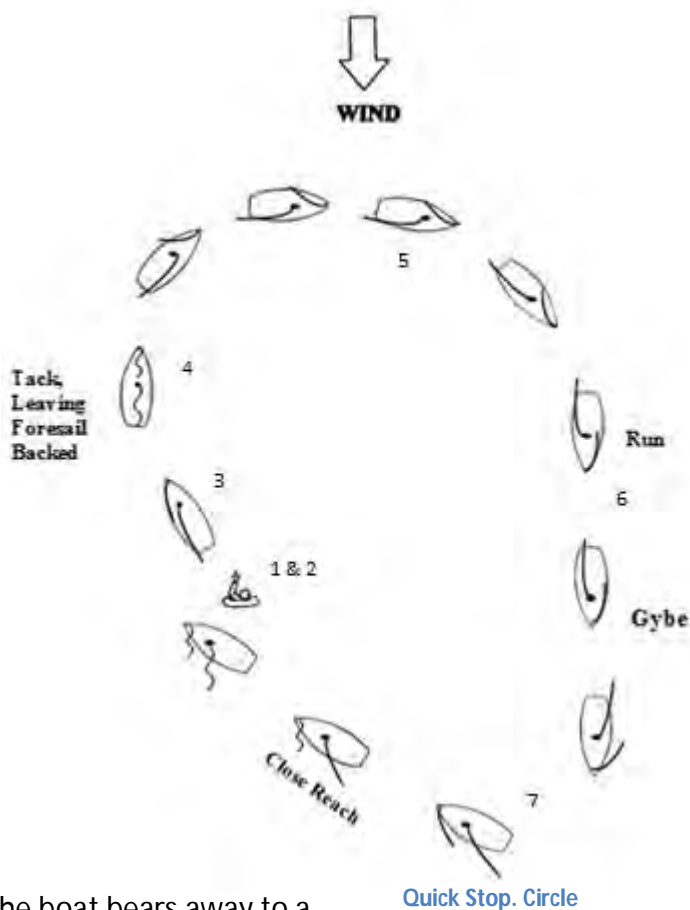

Several crew are desirable for the Triangle Method and there is a danger of sailing too far away and losing sight of the COB. Using the Quick Stop the returning vessel remains closer to the COB and the method is compatible with use of a Lifesling. The disadvantages come from the

necessity to gybe. It is very important that the mainsheet be fully hardened as the boat is coming to wind and left fully hardened through the gybe until eased for speed control during the final approach phase.

Quick Stop: Fast Return

This maneuver may be initiated from any point of sail but works best when sailing downwind on a reach.

1. Shout "CREW OVERBOARD!" Throw flotation and call "ARE YOU OK?"
2. Turn the vessel to a broad reach and sail one to two boat lengths.
3. Turn the boat toward the wind and tack.
4. Approach the victim on a close reach.
5. The sails are eased completely to slow the boat.
6. Recovery is on the side of the vessel appropriate to candidate condition and the situation.
7. Immediately secure the COB to the vessel, then lower sail if required.

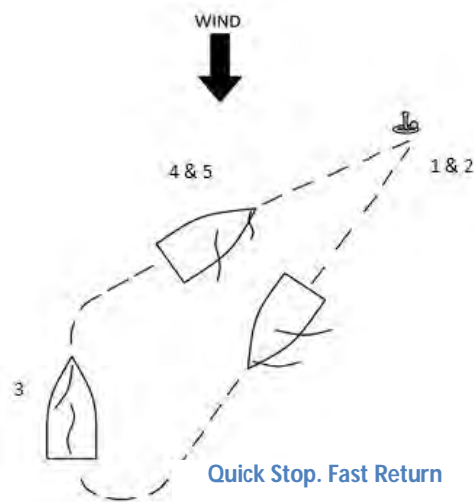

Recovery from the Water

After a successful return to the victim in the water you are faced with the task of getting him/her back aboard the vessel. As with all other aspects of sailing, plan ahead and practice. If the person in the water is capable of helping him/herself, you need get the boat no closer than the throwing distance of a buoyant heaving line. After throwing a buoyant heaving line to the person in the water, pull him/her to the boat to board via the boarding ladder.

Consider the placement of the boarding ladder. If it is on the stern, the rise and fall of the vessel in seas could be quite dangerous. Perhaps a rope ladder or stirrup over the side may be safer.

A person in the water that is injured and unable to assist creates other complications that will require forethought and planning. In this case the crew will have to maneuver the vessel close enough and slowly enough to make it possible to get the person in the water attached to the boat with a line or harness.

A harness or looped line under the arms can then be attached to a halyard to provide a mechanism to lift a heavy adult above the deck and back aboard the boat. The 'Lifesling' harness is a convenient way to achieve this. Don't overlook the dinghy as an intermediate step that may be an easy way to get a COB out of the cold water. Partially deflating one side of the dinghy will eliminate the freeboard further, making it easier to 'roll' the crew overboard into the dinghy.

Another alternative would be to use the headsail as a 'hammock' to lift the victim horizontally back aboard the boat. To do this, harden the sheet on the headsail so that the foot of the sail is tight.

Ease the halyard, lowering a section of the sail into the water. The victim can be manoeuvred into the sail and as the sail is raised again, the COB will be pulled up to deck level.

Each of the above methods can be effective on a variety of boats across a range of conditions.

But practice is essential to see what is possible on any particular vessel. Do not put someone in the water to practice. With the boat alongside the dock, try lifting someone to deck level from a prone position on the dock.

Methods of recovering the COB.



Boarding ladder



Partially inflated dinghy

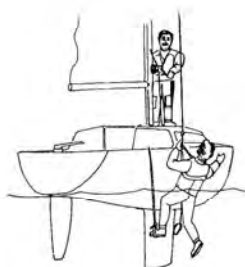

Line draped over hull, and halyard

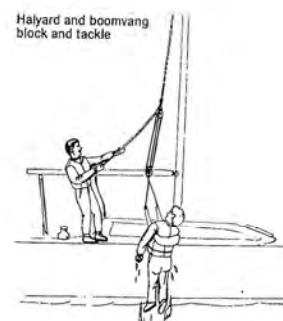

Halyard and boomvang block and tackle

26. Describe three methods of recovering fouled anchors.

A "fouled anchor" is the term used to describe an anchor that we cannot pull free from the bottom. The anchor can become stuck in a soft bottom and the suction of mud/sand or clay may not let it go. A fouled anchor may also be caused by the anchor actually hooking into something on the bottom such as a log, a rock or other object. In an abandoned log storage area, the anchor may have fouled with a boom chain or scrap cables.

If you suspect there may be foul ground below, anchor with a trip line and buoy. Anchoring with a trip line and buoy may provide an easy solution to recovering a fouled anchor. To set a trip line as illustrated, attach one end of a buoyant line to the crown of the anchor, the other to a float. The line must be at least as long as the depth of the water at the spot where the anchor is lowered plus some extra length to allow for any tidal height increase. As rode is payed out so is the trip line, which is released to float free when the anchor reaches the seabed. To retrieve the anchor, when above the anchor during raising, pull on the trip line to tip the anchor into a position where (hopefully!) it will release any object fouling the anchor.

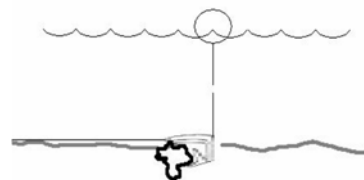

Trip line and buoy

If the anchor is just stuck in mud, pull the anchor line as tight as possible while several crewmembers are on the foredeck with you. Cleat off the anchor line and then return to the

cockpit and wait a few minutes. The buoyancy of the bow will hold a steady strain on the anchor and eventually the suction will break and the anchor will come free, usually in a few minutes.

To speed up the process with the scope reduced to nearly 1:1 you can motor around the anchor to break its set. Another strategy is to back away from the anchor in the opposite direction to that in which that you set it.

Another method may be to shorten scope to 1:1 and wait for tidal height changes or wave motion to break the anchor free.

A fourth method is to rig an anchor chaser to lasso the anchor and pull it out similar to using a trip line.

Simply tie a bowline around the anchor line with a sinking line.

Using a dinghy, row away from the boat out over and past the anchor.

The bowline will slide down and

over the anchor chain and anchor shank until it hooks the flukes. Pull this trip line to extract the anchor from the bottom or from whatever object has fouled it.

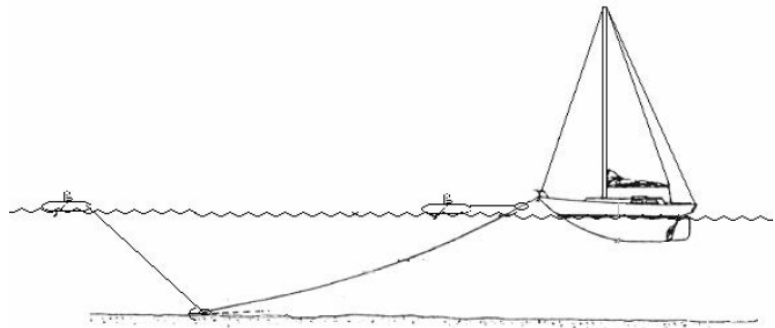

If you are not able to recover your anchor, attach a marker float and disconnect the anchor line so you can return later with a diver.

Rigging an anchor chaser

27. Describe options for stowing and securing a dinghy when snugging down for the night.

Few things are more frustrating than being awakened in the middle of the night to the constant bumping of the dinghy against the hull. Options for stowing and securing a dinghy when snugging down for the night include:

1. Hauling the dinghy up onto the deck.
2. Rafting the dinghy alongside with adequate fenders and spring lines.
3. Securing the dinghy tight along the transom with fenders and spring lines.

According to the [Caribbean Marine Association](#), dinghy and outboard motor theft ranks amongst the highest yacht related crimes committed in the Caribbean. They advise yachters to pull their dinghies out of the water at night and make sure that they are properly locked to the vessel.

28. Describe handling considerations (including stowage, launching/retrieving and towing) and differences between an inflatable dinghy, a rigid inflatable boat (RIB) and a rigid dinghy.

TYPE	Inflatable Dinghy	RIB Dinghy	Rigid (Hard-Shell) Dinghy
DESCRIPTION	Inflatable sides with flat, soft bottom. Some have slatted floors and plywood transom.	Inflatable sides with a rigid hull bottom made of fibreglass or injection molding.	Fibreglass construction. V-shape hull.
STOWAGE WEIGHT	Folds into package. Medium weight.	On davits or on deck. Heavy weight.	On davits. Light weight.
ABILITY TO LAUNCH AND RETRIEVE FROM SHORE?	No. Must be launched and retrieved from water. Must be lifted on beach with care.	Yes. Rigid bottom can be pulled up on or launched from beach with care.	Yes. Rigid hull can be pulled up on or launched from beach with care.
TOWING ABILITY	Poor. Flat bottom does not give any directional stability.	Excellent. V-shape hull gives directional stability.	Good. V-shape hull gives directional stability.
OUTBOARD POWER	Low-medium HP	Medium-high HP	Low HP
PLANING ABILITY	Will plane	Planes easily	Planes easily
MANOEUVRABILITY	Poor	Excellent	Good
STABILITY	Medium. Slatted floors make boarding easier.	High.	Low. Weight distribution is essential.
ROWING ABILITY	Poor. Flimsy oarlocks	Good	Excellent
SAILING ABILITY	No	No	Yes with kit
COST	Medium	High	Low
REPAIRABILITY	Temporary patch Professional repair	Temporary patch Professional repair	Relatively easy with Fibreglass resin and/or cloth kit

Towing

Care must be taken when towing a dinghy. If traveling a short distance in calm conditions it is easy to tow the dinghy instead of hauling it out, but rough seas and strong winds can flip a dinghy over.

Most dinghies will 'yaw' when being towed, especially if the tow line is attached directly to the bow. One solution is to use a 'bridle' configuration in the tow line rather than the line fixed to a single point on the dinghy. On Inflatables and RIBs, the bridle line should start at one side of the dinghy transom where there are often attachment points and then go forward and over the side, down through the D ring and then forward to a point about 2 feet in front of the bow. From here the line should continue and simply go in the reverse direction down the opposite side of the dinghy, back to a fixing point on the transom.

The tow line should be attached directly to the bridle to take the load and it is also wise to still attach the tow line to the bow as a backup, but leave some slack between the bridle and bow. With a bridle most dinghies will track fairly straight through the water, but in rough seas the only safe way is to haul it out.

Most Inflatables, and RIBs, have D rings bonded underneath the air chambers near the bow. These might appear quite strong but they are not really adequate for the high towing loads that might occur. After a while you will see the fabric

starting to tear. They are better suited to a job as a 'fairlead' to correctly position the bridle line. The transom is where the towing load should be directed, especially on full inflatables without a rigid hull.

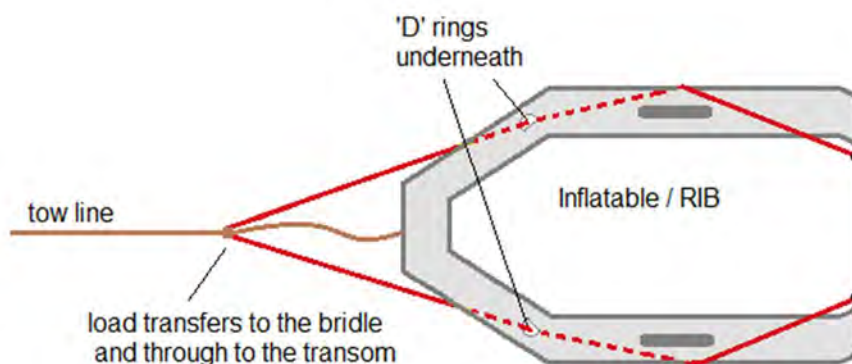

Proper bridle configuration

29. Describe precautions for safe handling of an outboard motor for the tender and actions to take in the event of accidental submersion.

Remember that once the tender is equipped with a motor, its boat type changes as does the minimum safety equipment requirements. Also, don't forget that you will need to carry proof of competency (PCOC) on board when operating the motor.

When operating an unfamiliar outboard motor and dinghy for the first time, take a moment to familiarize yourself with the dinghy's Compliance Notice and how to safely operate the motor. Every engine is unique and responds differently when you advance the throttle, change gears, turn, or get the dinghy up on a plane. Before accepting passengers aboard, a safe practice is to get to know the motor and dinghy's unique handling characteristics by doing some figure eight drills in forward and reverse, first at a very slow speed and then with more confidence at a higher speed. Identifying the pivot-point of the boat and stopping distance will help in mooring.

Knowing how the motor and dinghy respond, its stability and turning radius are essential for safe handling.

When carrying passengers consider weight distribution to maintain proper boat trim. Always advance the throttle slowly. Slow down when approaching waves and avoid quick turns.

In calm conditions the outboard can be safely left on the dinghy when towing. However, if rough conditions are anticipated the motor should be removed from the dinghy. There are slings and tackle available to raise and lower the outboard. If your vessel does not have one you will have to rig one up using a spare line.

If the outboard is accidentally submerged, recover it immediately. Take it to a dealer to be serviced to minimize corrosion. If this is not possible proceed as follows:

1. If submerged in salt water, rinse off the engine.
2. Drain the carburetor.
3. Drain and re-fill the crank case with fresh oil if a 4-stroke engine.
4. Remove the sparkplug(s) and turn the engine over to expel any water in the cylinder(s). Rinse out if seawater. Pour in a small amount of oil and turn over by hand to lubricate the cylinder(s). Replace the spark plug(s).
5. If the engine was running when it was submerged it is possible there could be mechanical damage if it binds when cranked. Do not attempt to start it. It will need to be repaired.
6. Re-fill with fresh gasoline and restart.
7. After a few minutes of running, shut down and replace oil a second time.

30. Describe the methods of rafting at anchor and dangers involved.

“Rafting” is a term used to describe two or more vessels tied together either at dock or at anchor. You may need to raft at a public dock with all slips occupied, in which case it is legal and acceptable to raft up to 3 boats side by side provided you are not obstructing the waterway in case of fire or preventing other boats from accessing inside berths or a through channel.

The following precautions should be taken when rafting:

1. Ensure that an ample number of fenders are deployed at contact points.
2. Use breast and spring lines to prevent movement.
3. Stagger boats to prevent rigging entanglement, or raft bow to stern.
4. Have your ground tackle ready for deployment in the event of having to break the raft in the middle of the night. *Have a plan!*
5. Ensure that mooring lines are easy to cast off in the event of having to break the raft in an emergency such as a fire, dragging anchor or heavy weather.

RAFTING AT ANCHOR

Rafting at anchor is usually done with buddy boats so two or more groups can socialize. The vessel with the heaviest or most appropriate ground tackle (usually the largest vessel) should anchor, with scope appropriate for the load generated by all vessels in the raft.

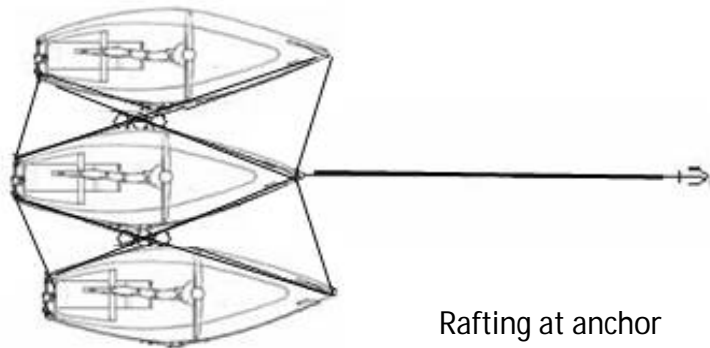

RAFTING AT A DOCK

Rafting at a dock requires the use of breast and spring lines to the boat next to you and, may include additional spring lines led to the dock. This provides for a very stable raft.

See PO 34. c) for a description regarding courtesy in crossing adjacent boats when rafted.

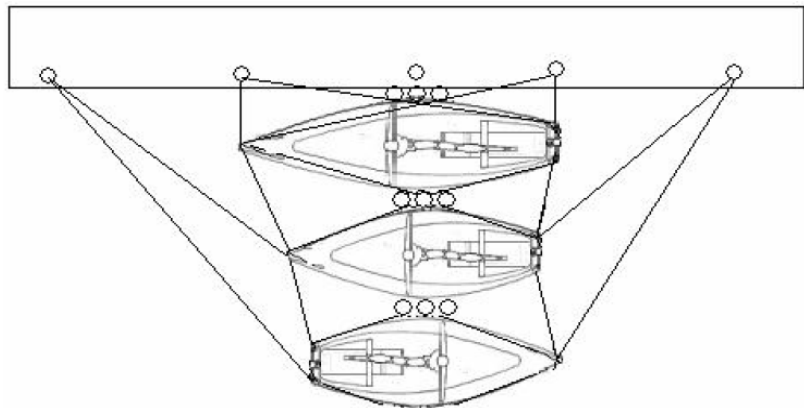

31. State the factors to be considered before allowing anyone to go swimming while the boat is at anchor.

Rafting at dock

Swimming is one of the pleasant activities associated with cruising; albeit one that requires a certain minimum water temperature for comfort. There are however, some precautions that need to be considered before diving overboard.

Naturally the boat must be anchored securely before considering swimming. Prior to swimming it is prudent to consider the re-boarding of the boat. It is highly embarrassing, not to mention dangerous, if everyone is in the water and no one has lowered the boarding ladder. In fact there should always be one person remaining on the boat to act as a lookout.

Before diving into the water consideration should be given to the depth of water around the boat as well as to the presence of wildlife such as sea snakes, eels, jellyfish and sharks. When in the water avoid touching coral or sea urchins. The normal hazards associated with diving into unknown waters exist. It may be safer to enter the water from a boarding ladder rather than by diving.

A major concern when swimming in an area used for anchoring is the level and proximity of boat traffic. A person swimming does not present a highly visible object for the operator of a boat under power and this is especially so in late afternoon when the sun is low. A swimmer should stay close to the boat and not venture into traffic areas.

In some locations the boat may be anchored in a current that can present difficulties for a tired or novice swimmer. For safety in this situation a buoyant 15 metre line with a fender attached can be tied to a stern cleat and allowed to float out in the current. A swimmer in difficulty can use this to assist them in returning to the vessel. In many locations there may be underwater hazards such as stinging marine life (e.g. jellyfish, fire coral etc.) that the swimmer must be aware of. In these types of locations an effort must be made in advance to determine the nature and presence of such hazards.

32. Describe the information required and the procedures to be followed when tying a boat to a fixed dock in local tidal conditions.

At some time you will encounter a fixed dock as the only available space to tie up. A fixed dock may be one with pilings supporting a dock platform which does not rise or fall with the changing of the water level, or it may be a rough concrete structure designed for larger commercial vessels. In either case there is a risk of damage to the boat and/or fenders.

To secure to a fixed dock you may need a plank to use as a fender board. The board is hung between the fenders and the dock pilings. In a pinch, an oar or spinnaker pole will suffice.

1. Ensure that the spring lines and bow and stern lines are long enough relative to the expected tidal height changes so that the vessel is not left hanging off its mooring lines.
2. Monitor the mooring lines and adjust as necessary with tidal height changes.
3. A kelleet or weight hung in the bight of the bow and stern line will hold the boat against the dock as the tide rises.
4. Rig a fender board that will slide up and down the pilings.
5. Check with local people regarding the bottom in the event that the area dries at low tide.
6. In the event that it does dry out and you opt to stay, consider the boats keel. Will the boat stand up or lean forward? You may have to rig a "leg" to hold the boat against the dock or under the bow or stern to prevent the boat from falling forward or aft. Adjust the mooring lines to compensate for the drop.
7. Rig a line from the mast to a point on shore to lean the boat against the dock.

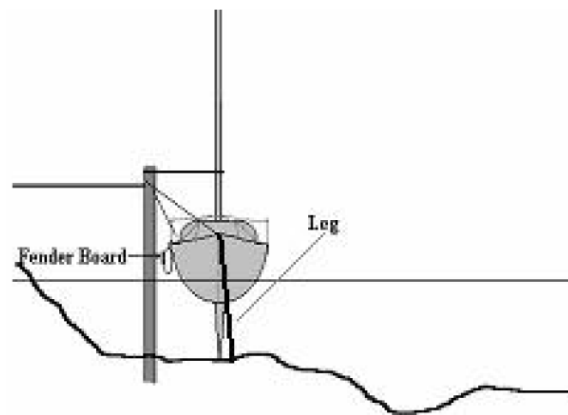

Tying a boat to a fixed dock

33. Describe how to secure the boat with an anchor on the bow or stern and the other end made fast to dock or shore.

The term “Mediterranean Moor” refers to anchoring your vessel, with either a stern or bow anchor, and securing the opposite end of the vessel to a dock or shore. Mediterranean harbours are very crowded. To accommodate more boats, the boats are tied stern to docks or quays side by side with anchors set off the bows. This method of securing works well in many places in Canada. It can be adapted so the stern is tied to the shore.

STERN LINE TO DOCK – Mediterranean Mooring

As with any anchoring, be sure to deploy enough rode to give sufficient scope. Due to possibly heavier side forces caused by wind shifts you will still need about 5:1. Calculate the amount of scope you will require for your stay and move appropriately far from the dock. Lower your anchor and back toward the dock. Set your anchor and test it using reverse power. When you are convinced that the anchor is set and will stay, continue backing toward the dock while veering out the anchor rode. Fenders protecting the stern as well as the sides of the vessel should already be in place. Secure the stern using spring lines. When securing the stern of the vessel, attach the windward line first, crossing the lines as shown in the diagram. Once the stern is secured to the dock, tension the anchor line to pull the vessel in line between the dock and anchor. As depicted in the diagram, three boats occupy the same space as would one vessel tied alongside.

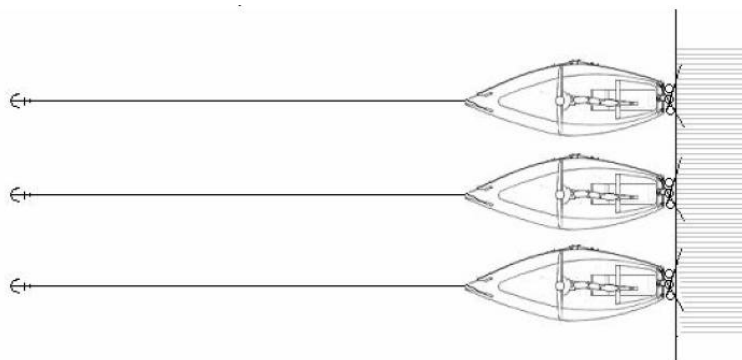

Mediterranean Mooring

Many marinas in Europe have gone an extra step and laid down pre-set anchor lines ‘lazy lines’ out in front of the docks. The dock spaces may be numbered and each space has its own lazy line ready for the incoming boat to use. This means you do not have to set your own anchor and it obviously simplifies the Med docking process. When you arrive and are assigned a dock number, just reverse your boat to the dock at the assigned space. Once your boat is in position and you have the stern secured you can step off onto the dock where you will find a thin connector line that leads to the heavier anchor line. Just pull up on the connector line as you walk toward your bow and eventually you will lift the anchor line off the seabed and be able to attach it to your bow. Finally, tension the anchor and stern lines to position the boat just clear of the dock, allowing for the necessary tidal height change.

With these pre-set lazy lines there is no risk of fouling your neighbour’s anchor and your departure is much simplified as well.

STERN LINE ASHORE

If you are securing a line ashore, avoid tying to a live tree to prevent damage to the bark. Many marine parks on the coast have eyebolts embedded in the rocks for stern ties. Check the depth of water near the shore to determine how close you may bring the vessel. After setting the anchor, back toward the shore until you are as close as you want to be. Using the dinghy, row ashore with a stern line and pass it through the eye bolt and bring the end back to the boat. By having both ends at the boat you do not have to go ashore again to cast off in the morning or during the night in the event of an emergency or if the wind freshens.

34. Describe a seamanlike method of preparing a boat in order that it may be left at the dock or on a mooring for a period of a week or more without crew.

How a boat is snugged down at the dock or on a mooring conveys a skipper's attention to detail and safety awareness. It's a clear indication of good seamanship. Follow this checklist for preparing to leave a boat unattended for an extended period:

- Empty the holding tank and flush the discharge line with fresh water to prevent odors.
- Refuel. It prevents condensation in the tanks.
- Make sure the boat is docked or moored in a protected location with sufficient depth throughout the period.
- Secure the boat so as to provide limited movement and position fenders correctly. Fasten fenders to the vessel at the same height with a round turn, two-half hitches.
- Centre the helm and secure in place.
- Put the dinghy on the forward deck or suspend on davits. Stow the dinghy oars and equipment in a lazarette.
- Level the boom so that it is parallel to the deck and restrict its movement by securing the topping lift, boom vang and main sheet.
- Ease the tension on the outhaul, cunningham, backstay and reef lines if necessary. Finish flaking the mainsail neatly on the boom.
- Silence all the halyards to prevent them from slapping the mast and attach the mainsail cover. Make sure all the sail is covered.
- Place covers on the helm, dodger windows and winches.
- Fasten and neatly coil the running ends of all lines, sheets and halyards to keep them off the deck and reduce their exposure to the elements. Tie down or clip in any loose items (e.g. whisker pole).
- Make sure the sheets wrap at least once around a roller furling foresail so that it will remain furled in strong winds. Coil the foresail sheets and hang them from the pulpit not touching the deck, or wrap them around their winches with some tension on the sheets. Coil the furling line and hang from the pushpit.
- Switch off circuit breakers. Leave the automatic bilge pump in the "AUTO" position. Turn the battery switch(es) to "OFF".
- Close all seacocks that are below the waterline. If closing the engine seacock, attach a warning to the engine key or at the ignition switch.
- Close fuel tank valve on a gasoline powered boat. Close propane tank valve.
- If docked, connect shore power and turn on the battery charger. Turn on an AC space heater or de-humidifier if necessary.
- Tidy up cabin. Remove gear, garbage and perishable food.
- Lock-up the boat.
- Wash down the deck and cockpit.

35. Describe the responsibilities of skipper and crew for the following courtesies, customs and legal obligations.

There is a sailing etiquette based on many years of marine tradition. A sailor's right to privacy and quiet must be respected. At the same time sailors must be ready to come to the aid of their fellow mariners.

a) Permission to board – It is not proper etiquette to board a yacht without permission. Ask the skipper for permission.

b) Permission and entitlement to come alongside – As a general rule you cannot be denied access to the shore. If you must come alongside another vessel and raft to gain access to the dock, then no fellow mariner can say “no”. The underlying caveat at Canadian Public Docks is that you raft no more than three deep so as not to impede passage. Private docks and facilities make their own rules. If you must raft to gain the dock, ask permission of the other vessel's skipper. If there are no people about, choose the most appropriate landing and make fast. Ensure adequate protection to hulls and secure with breast and spring lines. If a skipper denies you rafting privileges you have two choices - argue the point or move along to a more welcome position.

c) Courtesy in crossing adjacent boats when rafted – When moored, anchored or docked don't infringe on another vessel's air or space. It is common courtesy not to cross from your vessel over another through their living space. Traditionally the cockpit area of a vessel is considered living space. If you must cross, move from your side deck to the next vessel's side deck, then forward before the mast or wheelhouse. Disembark from the side deck to the dock as appropriate. Return to your vessel the same way. Wipe your feet or remove your shoes before crossing and try to be quiet without rocking the vessel unnecessarily. Some considerate boaters will give you permission to transit their vessel through the cockpit. Wait for the offer! Remember respect and courtesy are requisite.

d) Rights of first boat at an anchorage – If you are the first to arrive at an anchorage, you have rights over others arriving after you. Much depends on the anchorage itself. If it is large with good holding and sufficient room to swing, pick your spot and drop the hook. If you choose to set a bow anchor only, later arrivals should follow suit. If you have set a bow anchor and a stern anchor or have tied stern to, late arrivals should follow your lead. If you are the late arrival do the same as the other vessels. Some anchorages do not allow flexibility regarding etiquette because of size or depth constraints. A good cruising guide or local knowledge will be most helpful.

e) Keeping clear of boats racing (even though cruising boats may be the stand-on vessel) – The collision regulations make no special provision for vessels racing. As a common courtesy most cruisers avoid racing fleets and let them have their fun. If you find yourself in the midst of a racing fleet as the stand-on vessel, then maintain course and speed.

In some instances “race courses” may be established and marked with special buoys. Something like an Olympic Event comes to mind where an exclusion area could be established. Check with your local racing community to find the latest information.

f) Flag etiquette:

(i) National flag – Fly your national ensign from a staff at the stern of your vessel or from the backstay. The ensign should be flown from morning colours (0800) to sunset. The national ensign is not flown by a vessel in a race. It can be stowed when out of sight of other vessels. If nobody is aboard, the flag need not be flown. When entering or leaving port, even at night, the ensign should be flown. The only flag that can fly above your national ensign is a church flag when services are being held. Oh – if the Queen is aboard then her standard takes precedence. Raise the flag quickly at morning colours and lower slowly with ceremony at sunset.

(ii) Courtesy flag – When visiting a foreign port, you should fly the courtesy flag, the national ensign of the country you are visiting from the starboard spreader. It should not be physically larger than your own national ensign.

(iii) Burgee / house flag – Your yacht club burgee can be flown from the top of the foremast of your vessel. Another option is to fly it from the starboard spreader, usually lower than a courtesy flag. A third option is to fly it from a short staff, called a jackstaff at the center of the bow pulpit. This allows the burgee to be visible on both tacks. This is common for power vessels.

(iv) Q Flag – The Quarantine flag, a yellow rectangle, has been used by mariners for decades to indicate that their vessel is healthy and that they request pratique (clearance). Fly this flag from the starboard spreader when entering a foreign port. It should be flown before you hoist the courtesy flag. After you have been cleared for entry, take it down.

g) Offering assistance to other yachts in trouble – Maritime tradition and both Canadian and International law compels us to come to the aid of our fellow mariners when they need assistance. There is a caveat stating that we should do so only without harm to our own vessel and crew.

If the situation is too perilous for you and your crew then help as best you can. You may be able to help coordinate assistance with SAR or another more suitable vessel.

The first thing to do is determine the type of assistance required. A tow to safe harbour may not be as risky as approaching a vessel engulfed in fire.

If offering a vessel a tow, discuss with the other skipper the consequences of any minor mishap. Note in your logbook the offer and acceptance of a tow. Rig your vessel properly and instruct your crew on their duties. There is risk for both parties.

In the case of more serious situations such as fire, sinking etc. assess the situation carefully before putting your vessel and crew at risk. If a vessel is on fire it would be best if the crew of the distressed boat abandoned ship and you recovered them from the water. Putting your vessel in close proximity to a burning craft is far too dangerous.

Remember the skipper responsibilities: **“SAFETY OF CREW AND VESSEL FIRST.”**

h) Alcohol consumption – Drinking and driving is against the law on land and on water. As the skipper of your vessel, you are responsible for the safety of your crew and for not putting other

waterway users in danger. Alcohol combined with sun, wind, the motion of the boat and general tiredness can dull your senses and physical coordination, and impair your judgment. Contact the local law enforcement authorities for information on legal alcohol limits, when you can consume alcohol and how alcohol can be carried on board.

36. Describe the characteristics, limitations and uses of the following rope:

a) Polypropylene,

c) Nylon,

b) Dacron (Polyester),

d) High modulus fibres (HMDPE).

For eons humans have made rope by weaving together fibres from many sources. Some cultures used skin and sinew from animals, others the fibres of plants or trees.

Vegetable fibre rope was used extensively until World War II. The most common fibres used were hemp, sisal and coir (from coconuts). Others included jute, wool, cotton and silk.

Natural fibre rope has many disadvantages. It swells and weakens when wet. Knots jam and break easily. In addition, rope rots, mildews and decays quickly. Sun and weather contribute to this deterioration. Contact with paint, solvents or chemicals accelerate the breakdown of the fibres. Their strength to weight ratio is low and they are bulky, requiring large storage space.

World War II was a turning point for the evolution of rope manufactured from synthetic material. Along with some new synthetic fibres such as aramid and vectran; nylon, polyester and polypropylene revolutionized the rope industry. They are the main rope-making materials today.

Polypropylene – Polypropylene is the weakest synthetic of the three, about 40 % weaker than nylon. It is also the cheapest to manufacture. The fact that it floats makes it highly useful in the marine environment. It is widely used for tow lines such as dinghy painters or waterskiing tow ropes. Heaving lines suitable for crew rescue are another application. Polypropylene has the following characteristics:

- It can deteriorate quite quickly when exposed to sun and weather. The line will appear frayed and when handled will be brittle.
- It has quite a hard texture and will slip on cleats or through your hands. Under load it can cut and burn your palms or fingers.
- It is best suited for low load jobs where its' buoyancy is the major requirement.
- It is available in a variety of bright colors.

Dacron (Polyester) – Dacron is a trademark of the DuPont Chemical Co. This polyester fibre is also very strong. It does not have very much stretch and even that can be removed by pre-stretching during the manufacturing process.

Dacron is much preferred for halyards, sheets or other rigging where strength is important but stretch is a detriment. It can be chafed through more quickly than nylon. Dacron is much easier on the hands and feels smoother than nylon.

It is about 10 % weaker than nylon. Dacron also does not float.

Nylon – Most of these new synthetics come from oil. Nylon is one of the strongest and the most elastic synthetic fibres. Its ability to stretch gives it great shock absorbing ability. It will stretch without damage to its fibres and is resistant to chafe.

Nylon rope is well suited for use as anchor rode, dock lines and tow rope. Climbers like it for its strength and shock absorbing ability. Because of its stretch factor it is not suitable for halyards and sheets. It is also rough on the hands of crew.

Nylon will not float, so be careful around props.

HMDPE (Spectra and Dyneema) – High Molecular Density Polyethylene is made from the same material as found in a typical plastic bag. It is very strong and lightweight. It has the unique property of the molecules of the material aligning themselves in the direction of the load. This phenomenon is exploited in the manufacturing process. The major disadvantage to this process is the “creep” factor. The initial stretch is very low but over time if the rope is carrying a load it will stretch, never to return to its original length. This creep effect is not critical in lines or sheets that are adjusted and eased regularly, but would not be suitable for applications such as halyards.

The early HMDPE rope was very slippery and had some stability problems. This has been overcome with more sophisticated manufacturing techniques.

It is an excellent material for rope construction because it is lightweight, strong and very resistant to sun and chemicals. Water absorption is almost nil and it will float.

Vectran – One of the latest synthetics to be developed, Vectran takes the molecular alignment principle found in HMDPE to another level. The manufacturing process uses electric current to align the molecules; this produces a very strong fibre with minimum stretch and no propensity to creep. It has good abrasion resistance and excellent strength-to-weight ratios. Vectran does not resist UV (sun) very well and is usually found inside a cover.

CHARACTERISTICS OF SYNTHETIC ROPE

Synthetic rope has high tensile strength and good sustained load performance. It absorbs shock. It is resistant to rot, mildew, marine decay and attack by chemicals, oil, gasoline and solvents. Deterioration from sun and weather is slower than that of the old vegetable fibre ropes. Limited water absorption helps keep synthetic rope breaking point constant when wet.

Manmade rope is easy to handle wet or dry. It is lightweight, easy to carry and stow. The rope has a high weight to strength ratio. Lines that float will do so indefinitely and all synthetics have good durability features and life expectancy. Knots may slip or come undone due to line smoothness. You may need an extra half hitch to secure them.

Oil-based synthetics melt when heated. This can be a problem if there is heat producing friction that may melt or weaken a line. Knots can be fused together, never to be untied, if too much heat is applied.

ROPE CONSTRUCTION

Braided Rope – Braided rope was developed to overcome the shortcomings of laid rope. The majority of braided rope is made up of an outer cover and an inner core. Braided rope has a low stretch factor and is much softer. It is more difficult to splice and may require some special tools and instructions from the manufacturer.

Braided rope manufacturers may combine synthetics to produce their particular rope. Covers may be one synthetic and the core another. Check the manufacturer's specifications for construction methods.

It is important to match size of rope to job requirement. Check the size of sheaves, blocks and winches. Your rigger and manufacturer will give recommendations



Laid Rope – In the beginning rope was laid or twisted from individual fibres. This process was performed on long narrow rope walks where the rope could be laid out full length. The manufacturing was essentially a manual process, complex and time consuming. Individual fibres were made into yarns. The yarns twisted into threads. Threads twisted into strands and finally the strands twisted together to make a rope. Eventually machines were developed to manufacture rope in infinite lengths.

Laid rope construction is very cost effective and widely used. Nylon dock lines and anchor rode are two everyday uses for laid rope. It is simple to splice and knot, with good strength. The process does produce stretchy rope, with hard finishes that are not easy on the hands.

Section V: Navigation and Passage Planning

37. Convert directions between true, magnetic and compass, using the compass rose on a current chart.

The navigator frequently needs to convert courses and bearings from degrees true to degrees magnetic or compass, and vice versa. For example, you may have been steering a compass course but want to convert to degrees true to plot the course on your chart. Another example, on official charts ranges are given in degrees true so you will need to convert from degrees true to degrees magnetic or compass to steer on a range.

The process of converting courses and bearings to true is known as **correcting**.

To correct from compass to magnetic and true, add easterly errors and subtract westerly errors. A memory aid for this is the word "CADET" (Compass Ad(d) East to find True).

To translate from true to magnetic and compass, subtract easterly errors and add westerly errors (the opposite of the above).

If you remember only the word CADET you can work out the rest of the foregoing as below:

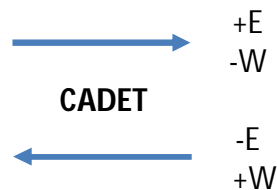

A simple way to make corrections is to lay out your work horizontally, as shown below, putting down the information you have, and then solving for the unknown(s).

Compass	Deviation	Magnetic	Variation	True
_____	_____	_____	_____	_____

A memory aid for the above is the sentence "Can **D**ead **M**en **V**ote **T**wice?" If going from true to compass (right to left), use "TV **M**akes **D**ull **C**hildren".

Example #1: Finding degrees magnetic and true (working to the right)

Compass	Deviation	Magnetic	Variation	True
057	5W	_____	23E	_____

Solution: Magnetic will be 057 degrees minus 5 degrees (from Deviation Table below) which equals 052 degrees magnetic. True will be 052 degrees plus 23 degrees (from chart) which equals 075 degrees true.

Example #2: Finding degrees magnetic, the deviation, and degrees compass (working to the left). Use the Deviation Table for the Yacht *Windswept* below to find deviation.

Compass	Deviation	Magnetic	Variation	True
_____	_____	_____	23E	327

Solution: 327 degrees true minus 23 degrees equals 304 degrees magnetic. Deviation from the Deviation Table for 304 degrees magnetic equals 3 degrees E. 304 degrees magnetic minus 3 degrees equals 301 degrees compass.

Sometimes when checking the deviation of the compass with a range you will find yourself in the situation of having to decide whether the degrees of deviation you see are Easterly or Westerly. Use this memory aid:

Error east, compass least (i.e. less)

Error west, compass best (i.e. more)

If, when setting up a CDMVT table as above, the compass degrees are less than the magnetic degrees, the deviation will be East. If the compass degrees are more than the magnetic degrees, the deviation will be West.

Note that bearings and courses are always given a three-figure notation. For example, a course of 97° is expressed and written as 097°.

Magnetic	Deviation	Compass
000	1W	001
010	2W	012
020	3W	023
030	3W	033
040	4W	044
050	5W	055
060	6W	066
070	6W	076
080	6W	086
090	5W	095
100	4W	104
110	3W	113
120	3W	123
130	2W	132
140	2W	142
150	1W	151
160	0	160
170	0	170
180	1E	179
190	2E	188
200	3E	197
210	3E	207
220	4E	216
230	5E	225
240	5E	235
250	6E	244
260	6E	254
270	5E	265
280	4E	276
290	3E	287
300	3E	297
310	2E	308
320	2E	318
330	1E	329
340	0	340
350	1W	351

38. Determine speed, time and distance when two are known.

Speed time and distance are interrelated elements of navigation. If you know two of them, you can find the third by applying the formula $D=ST$ (Distance = Speed x Time).

In coastal navigation it is convenient to express time in minutes so we modify the formula to read $60D=ST$. Remember: "Sixty D Street".

Sample questions and answers:

1. What distance is traveled if $S = 7.0$ kn and $T = 90$ minutes?

Solution: $60D = SxT$; $D = SxT / 60$; $D = 7x90/60$; $D = 10.5$ miles

2. What is the speed if you travel 2 miles in 20 minutes?

Solution: $60D = SxT$; $S = 60D/T$; $S = 60x2 / 20$; $S = 6.0$ knots

3. What time will it take to travel 15 miles at a speed of 6.0 knots?

Solution: $60D = ST$; $T = 60D/S$; $T = 60x15/6.0$; $T = 150$ minutes = 2 hours and 30 minutes

Caution: When adding and subtracting times, remember there are only 60 minutes in an hour!

39. Determine estimated time of arrival (ETA) and revised ETA.

To calculate your ETA (Estimated Time of Arrival) at a destination, first apply the $60D = ST$ formula above to find out how long it will take you to travel to your destination assuming a constant speed. Add this time to your time of departure to get the ETA.

Example:

How long will it take to travel 18 miles at a speed of 5.0 knots? If you leave your departure point at 1330 hours at what time will you arrive at your destination?

Solution : $60D = ST$; $T = 60D/S$; $T = 60x18/5.0$; $T = 216$ minutes = 3 hours 36 minutes

ETA = 1330 + 3 hrs 36 mins = 1706 hrs

Because life is never simple and small boats are subject to changes in weather and sea state, it is most likely that you will have to revise your ETA, perhaps more than once during a passage. Suppose during the above passage you encounter headwinds after you have been traveling two hours and have to reduce your speed to 4.0 knots, what will be your revised ETA?

If you are on time so far, you have traveled 10 miles, the distance remaining is 8 miles and the time is 1530 (1330 + 2 hours). Applying the formula for time, you find it will take exactly 2 hours at 4.0 knots to complete 8 miles. Therefore, your revised ETA is 1530 + 2 hours 0 minutes = 1730hrs.

It is useful also to work out a time of departure for embarking on a passage to enable you to arrive at a destination before dark, before the fuel dock closes or in good time for a rendezvous.

Apply the formula for time to determinate how long it will take you to travel to your destination.

Decide what time you want to be there and work backward to find out what time you should leave the point of departure. If you want to be at your destination at 1600 hours and it will take 6 hours to make the passage, you will need to depart no later than 1000 hours. It is wise to be conservative with estimates for time and speed when you are traveling on a small boat, especially a sailboat.

40. Identify sources of navigation information and use this information in route planning.

All vessels are legally required to carry appropriate charts and publications on board. An exemption is allowed for a mariner who has 'local knowledge'. A local fisherman who regularly operates in a small area may have sufficient local knowledge but a cruiser who ventures out infrequently and goes to new destinations will obviously not. As a skipper your responsibilities are the safety of the vessel and crew, and that clearly includes safe navigation.

OFFICIAL PUBLICATIONS

Official publications to be carried aboard while cruising are:

- Appropriate charts for the cruising area including the largest scale charts of harbours, anchorages, narrow channels etc.
- Chart #1 Symbols, Abbreviations and Terms** – the Introduction contains useful information and you should recognize and know the meaning of symbols in the following sections:
 - H – Tides, Currents
 - I – Depths
 - J – Nature of the seabed
 - K – Rocks, Wrecks, Obstructions
 - Q – Buoys, Beacons
- Tide and Current Tables** for the cruising area.
- The Canadian Aids to Navigation System**.
- List of Lights, Buoys and Fog Signals** for the cruising area. Each listing gives the exact position of an aid to navigation, the colour and flashing characteristic of each lighted aid, and the sounds emitted by fog signals.
- The International Regulations for Preventing Collisions at Sea (1972) with Canadian Modifications**, also known as the Collision Regulations or ColRegs. These regulations define a common set of rules that vessels on the water are expected to follow. These may also contain national modifications – the Canadian edition contains a number of Canadian Modifications. The Collision Regulations indicate which is the stand-on and give way vessel when vessels are approaching one another at sea or in inland waters, and also contain sections dealing with lights, shapes and sound signals, special circumstances and distress signals. A thorough knowledge and understanding of these regulations is necessary for anyone in charge of a vessel.
- Safe Boating Guide** – contains excerpts from the *Small Vessel Regulations* applicable to pleasure craft, in particular the Transport Canada required safety equipment to be carried aboard pleasure craft of certain lengths.

- ❑ Local Rules and Regulations* – rules laid down by the local harbour authority. Some of these may modify or supersede one or more rules of the Collision Regulations.
- ❑ *Pilot, Sailing Directions or Small Craft Guide* for the cruising area. These supplement information given on charts and give explicit directions for avoiding hazards and for entering harbours, often accompanied by photographs or sketches.

Publications must be current editions. *Canadian Notices to Mariners**, contain important navigation information including amendments to Canadian charts, *Sailing Directions* and *Lists of Lights, Buoys and Fog Signals*. Access is by the website www.notmar.com.

*Notices to Shipping** are posted online and broadcast daily on VHF radio and subsequently may be included in *Notices to Mariners*. They inform of hazards to shipping and aids to navigation that are not functioning.

Safety Tip: Familiarize yourself with all the official publications and with the navigation equipment aboard the vessel you are currently sailing.

SOURCES OF LOCAL KNOWLEDGE

- ❑ Cruising Guides for the cruising area. These are not official publications but are authored by cruising people who have extensive knowledge of the area. Many are attractively presented with photographs and drawings and contain a wealth of information of interest to the cruising sailor. They cover not only marinas, facilities, anchorages and marine parks but deal with such topics as local history, natural history, trail walks, and local attractions. Buy recent editions and be aware that there may be the occasional error in navigational information.
- ❑ Talk to Coast Guard personnel, harbor masters, marina staff for up to the minute local details. Chatting up local boaters, fishermen and residents may prove worthwhile and can provide wonderful entertainment but be skeptical of the “information” provided.
- ❑ Tourist information offices can help with planning trips ashore.

**These publications are available online for free downloading.*

APPENDIX I: PASSAGE & PILOTAGE PLANNING

The Intermediate Cruising course will provide opportunities to apply the navigation skills taught in the Basic Coastal Navigation course including elementary passage and pilotage planning, non-electronic position determination methods, and basic use of satellite positioning systems.

Candidates are expected to be able to competently demonstrate the knowledge and skills developed in the Basic Coastal Navigation course.

PASSAGE PLANNING

There are several factors to consider before leaving a dock to embark on an extended voyage. A passage plan is a four-stage process that skippers are legally required to carry out from start to finish or “berth to berth” to execute a safe and efficient voyage. The four stages are:

1. Appraisal
2. Planning
3. Execution
4. Monitoring

The appraisal stage consists of gathering and examining all information relevant to the voyage. This includes the vessel, crew and area travelled. **Before leaving the dock**, you will want a thorough understanding of your vessel’s specifications, condition and operational limitations. You will also want to know of any crew limitations, medical considerations or dietary restrictions. With these factors in mind, you can then consult the nautical charts and publications, tide and current tables, local regulations, notices to mariners, notices to shipping and weather forecasts to plan your route.

The planning stage involves laying out the voyage with consideration of all the information gathered in the appraisal stage. It will include plotting a route from berth to berth on the largest scale chart applicable using a series of straight lines (courses or tracks) that you intend to take while keeping clear of any hazards. Remember to properly label your course lines as suggested in your Coastal Navigation textbook or *Sail Canada’s Uniform Navigation Symbols and Terms* (available online). If you are plotting a route using electronic charts, record each course line and waypoint in your Navigator’s Notebook or Log. Record your courses in True on the paper chart but correct them to Magnetic using your Navigator’s Notebook or Log. You can correct them to Compass using the vessel’s deviation card once on board.

On the chart, mark objects such as lighthouses and transits, and plot clearing lines to define the limits of safe navigation for any narrow passages or dangerous areas enroute.

A complete passage plan will contain details for the entire voyage from berth to berth including the availability of contingencies in case of emergency.

PILOTAGE PLANNING

Once you have plotted the entire passage, you will want to make specific notes to have ready and at hand when piloting into and out of dangerous or unfamiliar areas. This is what is referred to as a pilotage plan.

A pilotage plan relies more on visual references rather than plotting and charting. The person on the helm still needs to steer a course but the progress and position of the vessel is monitored by reference to land features, fixed objects on land, and aids to navigation such as channel markers. Use *Sailing Directions*, cruising guides and other navigation publications as well as any local knowledge to inform you as much as possible about the area.

This is an example of a pilotage plan for Shoal Channel located near Gibsons, British Columbia.

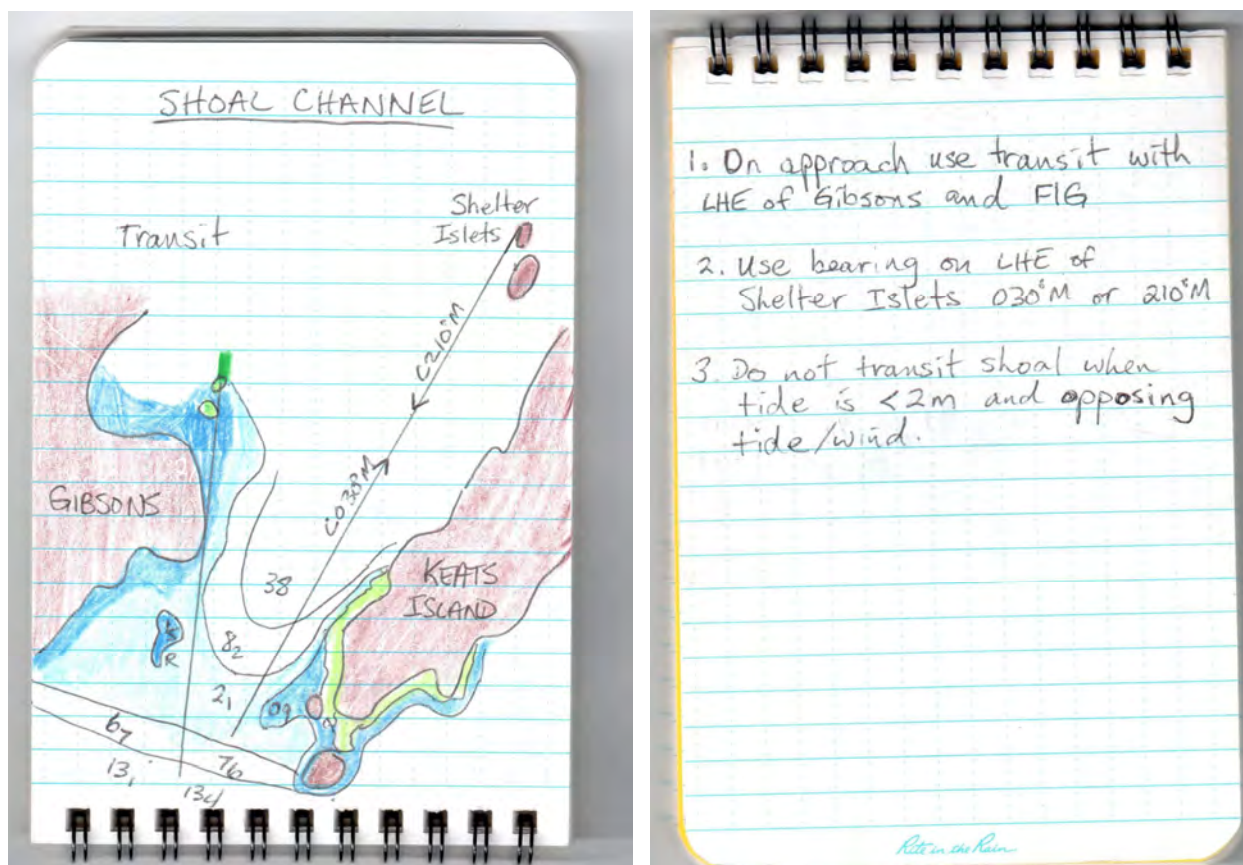

Notice that this pilotage plan provides three relevant checks for the navigator to refer to when transiting:

1. Contour lines with depths to signal the approach and location of the bar;
2. A transit off the steep side of land and a port hand daybeacon. The pilot must alter course to the centre of the channel before the visual on the daybeacon is hidden;
3. An approach bearing (030 M) or back bearing (210 M) on the Left Hand Edge (LHE) of Shelter Islets.

A pilotage plan is drawn up for confined areas you plan to visit or transit during your passage. A passage plan may contain several of these detailed pilotage plans.

Tips for Drawing Up Pilotage Plans

- ✓ Find a suitable method for creating, accessing and saving your pilotage plans. The above sketch and notes are produced on waterproof pages in a pocket-size notebook. Other methods include tracing, sketching (it doesn't have to be in colour) or taking a photo of your chart work and laminating the paper or storing it on an electronic device.
- ✓ Include written notes of what to expect so you don't have to refer to bulky publications.
- ✓ Draw the course of your planned route to pass some easily recognized marks to keep track of your progress.
- ✓ Check along the course to see if depth of water is going to be an issue and if so, note the tidal information for the time of your passage.
- ✓ Check the published information for VHF channels used to monitor traffic movements or if you are calling a marina.
- ✓ **Don't rely on one method of fixing**, cross check your position using multiple techniques such as: using a chartplotter (depending on accuracy of chart and GPS); lining up two charted objects to keep you on the correct course; using an approach or back bearing on a charted object; and, depth readings from your depth sounder.

Note that you have done all this work and have yet to leave the dock!

As your departure date nears, you are watching the weather forecast (7-5-3 day, 24 hour outlook) from Environment Canada (and your favourite wind/weather apps) for any last minute changes you need to consider.

FILING A SAIL PLAN

Once the passage plan is set based on the current weather forecast, it's a good time to share your vessel, crew and passage plan details with a responsible person staying behind. Instruct them to contact a Rescue Coordination Centre and/or the nearest Search and Rescue (SAR) Team if you do not arrive at your destination as planned. If you are taking a long trip, file a daily position report (especially if your planned route has changed).

EXECUTING AND MONITORING THE PASSAGE PLAN

Now that passage plan is complete, it's time to cast off your lines and execute the voyage as planned from berth to berth. But remember, conditions may change resulting in executing one or more contingency plans. The bottom line is that the more planning that is done in advance, the less time you will require on the water to adapt to any conditions or situations you face.

The Intermediate Cruising course provides the ideal learning environment to practice and apply your passage and pilotage planning skills before heading out on an extended voyage on your own.

APPENDIX II: SAIL TRIM THEORY

Sail trim theory and practice is dealt with in more detail at the Advanced Cruising Level. What is noted below is appropriate to meet the Intermediate Cruising Standard.

FORESAIL SAIL TRIM

As the clew of the foresail moves forward (with furling) or aft with unfurling, the foresail sheet blocks (jib cars) should also be moved forward or aft to optimize the sheeting angle, tensioning the leach and foot equally. Another view is to position the car so that a line, extended from the tensioned sheets, intersects the midpoint of the luff of the foresail.

When reefing the foresail, move the blocks forward; when un-reefing, move the blocks aft. A basic rule for initial positioning of the foresail sheet blocks is as follows:

- When sailing upwind (beam reach, close reach, close hauled), the foresail sheet should point to the midpoint of the luff of the sail, when the sail is trimmed;
- When sailing downwind, move the blocks aft to maximize the ability to expose sail surface area to the wind.

Telltails should be fitted near the luff in at least three positions up the luff. When the foresail block is positioned correctly and the sail properly set, these sets of telltails should behave similarly. When sailing upwind, the telltails on the inside and outside of the sail should be flying aft. When close hauled, the inner telltails should occasionally droop.

On a close haul, close reach, or beam reach, trim the foresail first. On these points of sail, foresail trim will affect the trim of the mainsail. As sails are more efficiently trimmed, boat speed may increase, leading to a need for additional minor adjustment to sail trim.

MAINSAIL SAIL TRIM

The traveler can be used to control the power of the mainsail, and the heel of the vessel. Prior to reefing, with building wind strengths, the traveler car should be lowered to leeward, and the main re-sheeted, to reduce weather helm and leeway. However, with continued building of wind speeds, true or apparent, a decision to reef will still be required.

Close hauled in very light winds, to provide more power from the main, the traveler car should be raised to windward to position the boom amidship, effectively compensating for the sag of the boom caused by the natural tendency of the mainsheet to sag to leeward.

When sailing downwind, lower the traveler to improve sheeting angle and to aid the boom vang in flattening the mainsail.

On the mainsail, telltails are ineffective near the luff of the sail because of turbulence near the mast and back winding from a sheeted-in foresail. Telltails are fitted near the battens on the leach of the sail. The mainsail telltails should stream aft, with the top telltale streaming aft at least half of the time. The top batten should be parallel to the boom when sailing close hauled.

SAIL TWIST

If you look up the leech of a sail you will see that the upper part of the sail twists to leeward. The amount of this twist can be controlled so that the sail is producing lift over all of its height as the wind is not constant in speed at different heights. Near the surface of the water frictional effects slow the wind significantly, especially in wavy conditions.

To let the top of the sail out we induce twist. Twist is increased by easing the tension on the leech of the sail to allow the top of the sail to fall off the wind. We recognize correct twist by looking at the telltales up the sail. Deliberately inducing twist depowers the sail; such as in a gust, you can ease the mainsheet to reduce heel.

FORESAIL SAIL TWIST

We can check twist by momentarily luffing up and watching the windward telltales. If the top telltales luff first, the upper part of the sail needs to be tensioned (less twist); move the cars forward to tension the leach to reduce twist. If however the lower telltales luff first, the foot needs to be tensioned (more twist) by bringing the cars aft.

MAINSAIL SAIL TWIST

The twist in the main is increased by easing the mainsheet or by easing the boom vang. When the mainsheet is eased, the traveler may need to be moved to windward. Conversely hardening the main and bringing the traveler under the boom (the traveler may need to be moved to leeward to maintain boom position) and hardening the boom vang reduce twist.

GLOSSARY:

Barometer – An instrument measuring atmospheric pressure in millibars.

Bearing – Direction from one point on the earth's surface to another.

Binnacle – Housing for the steering compass, usually set on a pedestal.

Bulkhead – A vertical partition on a vessel, corresponds to a wall in a building

Cocked hat – A small polygon formed by three or more intersecting bearing lines on a chart.

Compass rose – A circle printed on a nautical chart used to lay off courses and bearings. The outer ring is oriented to true north. The inner ring, if there is one, is oriented to magnetic north.

Contour line – A line on a chart or map connecting points of equal depth or elevation.

Course – The intended direction of travel.

Course Line – A line drawn on a chart representing the intended direction of travel.

Current – The horizontal motion of water; may be tidal or ocean current.

Depth sounder – An electronic depth measuring instrument that measures the time a sound wave takes to go from the vessel to the bottom and return.

Dead Reckoning (DR) – A position based upon direction, speed and time from a fix.

Deviation – The angle, measured in degrees, that a compass needle is deflected from the magnetic meridian. Deviation is caused by magnetism in the vessel. Deviation is labeled East or West.

ELCI – Electric Leakage Current Interrupter. Similar to GFCI. See GFCI.

Fix – A known position at a specified time.

GFCI – Ground Fault Circuit Interrupter. A device that detects a situation that may indicate current leakage through the body of a person who is grounded and accidentally touching the energized part of the circuit. This situation may lead to electrocution. The GFCI will cut power eliminating the risk.

Great Circle – A circle that divides the earth into two equal parts, passing through the center of the earth. The meridians of longitude are Great Circles.

Hand bearing compass – A portable compass designed for taking bearings.

Heading – The direction in which the vessel is pointed. Not necessarily synonymous with "course", for example, when the helmsman steers a heading above or below a course in order to counteract the effect of a strong current.

Knot – A speed of one nautical mile per hour.

Latitude – Distance north or south of the equator. The measure of the angle formed by a line drawn from a point on the earth's surface to the centre of the earth and the plane of the Equator.

Leadline – A marked length of line weighted with lead used to measure the depth of the water.

Line of Position (LOP) – A line drawn on a chart along which the observer is presumed to be.

Log – An instrument which measures a vessel's distance traveled and /or speed through the water.

Longitude – A measure of the angle between the planes of two meridian circles, one of which is the Prime Meridian.

Lubber line – The index mark on a magnetic compass that indicates the direction in which the vessel is pointing.

Magnetic course – Direction of travel in relation to local magnetic north.

Mediterranean moor - refers to anchoring your vessel, with either a stern or bow anchor, and securing the opposite end of the vessel to a dock or shore.

Meridian – A Great Circle through the North and South Poles.

Nautical Mile – A distance of 6076 feet or 1852 metres.

Range – Two prominent objects or lights in line. Also known as a transit or leading line.

Rafting - a term used to describe two or more vessels tied together either at dock or at anchor.

Relative bearing – A bearing relative to the vessel's heading.

Ship's log – A book in which navigation information is recorded.

Sounding – Water depth measured in feet, fathoms or meters at a location.

Track – The actual path of a vessel over the ground.

Variation – The angular difference in degrees between true north and magnetic north. Variation is labeled East or West.

SUPPLEMENTARY PUBLICATIONS:

Basic Coastal Navigation. Gillian West. Revised 2018.

Basic Cruising Skills. Gillian West, SAIL CANADA

Boatowner's Mechanical & Electrical Manual. Nigel Calder. International Marine/Ragged Mountain Press; 2 edition (Nov 1 1995).

[Canada Shipping Act, 2001 - Environmental Protection](#).

<http://www.tc.gc.ca/eng/mediaroom/backgrounders-b07-m006-1887.htm>

Coastal Cruising Made Easy, Harry Munns, American Sailing Association

Chapman Piloting & Seamanship. Elbert S. Maloney. Hearst 65 edition (Sep 28, 2006)

Cruising Fundamentals, Harry Munns, American Sailing Association.

Marine Weather Hazards along the British Columbia Coast. Environment Canada.

Marine Weather of Western Washington. Kenneth E. Lilly, Jr., Starpath School of Navigation.